

FISCHBACH- Air Handling Units

... and lowest noise levels

the heart of every FISCHBACH AHU:
Fischbach Compact Fan
- The silent one -



Ventilating



Heating



Cooling

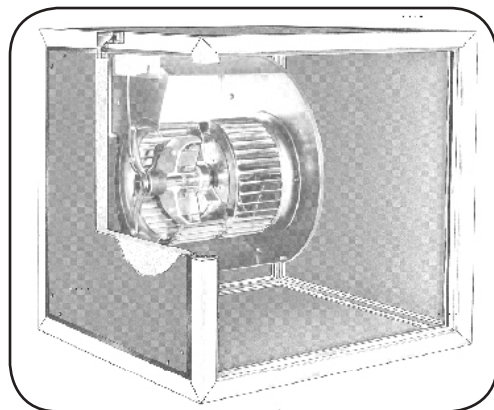

Standard Series, Size 1 - 4: up to 32.000 m³/h



**Flat Series,
Size 1 - 5**



**Advanced technology in Super-Flat
format: Flat Series up to 9.000 m³/h
with heat recovery system**



FISCHBACH
Luft- und Ventilatorentechnik GmbH



FISCHBACH - Air Handling Units

AIR HANDLING UNITS

SOME OF THE BENEFITS:

- **Casing panels** with P.V.C. frame, in double skin construction **41 mm deep**
- Insulation of mineral fibre with high insulation value
- **Higher effective double-edge rubber seal** fitted all around the P.V.C. frame for high pressure differentials
- Improved weather-proof properties
- Robust **quick release locks** (rotating 90°), fully countersunk, fitted into P.V.C. frame with **large contact area**
- Operated by means of hexagonal spanner SW 6
- Casing panels removable (**interchangeable**), inspection side hinged or with T-handle if required
- Smooth internal surfaces that can be wiped clean, no protruding catches, therefore easier maintenance and inspection
- Overall design extremely soundproof
- Main casing frame construction from robust **ALUMINIUM PROFILES** with internal corner pieces
- Main frame of hollow load bearing profile separated from the internal frame by P.V.C. struts. The internal frame has „T“ grooves for attaching the various elements of the unit. If necessary, these elements can be fitted during site installation
- Intermediate supports on larger modules to strengthen and fix the side panels
- **High sealing according to class D III, VDI3803**

Ventilator Unit	Can be taken out from access side after unfastening of 4 screws. Easier handling and cleaning. Easy change of the fan due to higher performance.
Air Heater Unit	Heater can be taken out from access side. Easier to inspect and clean.
Electric Air Heater Unit	Heater can be taken out from access side. Easier to inspect and clean Easy electrical connection on site. Partially higher performance.
Air Cooler Unit	Cooler, moisture eliminator can be taken out separately for inspection and cleaning purposes. Drain tray can be removed on access side Sloping drain tray provides immediate drainage of condensate. Drain tray in stainless steel. Up to 11,2% larger cooler surface.
Air filter Unit	Filter inserts can be taken out from access side . Easy to inspect and easy to change. Filter inserts 195 mm long in EU4. Filter inserts 600 mm long in all filter classifications up to EU9/F9 available. Filter inserts 600 mm long with asurface of 4.9 sqm.
Attenuator Unit	Easy inspection and cleaning of the inserts. Construction length according to space.

FISCHBACH - Lüftungs- und Klimatechnik

Coarse Filter Unit	Coarse- and Fine filter inserts can be taken out from access side. Easy to inspect, clean and change. Internal slopes immediate condensate drainage. Easy to clean drain tray. Stainless steel drain tray. Connection of a condensate drainage pipe possible
Activated Carbon Filter Unit	Survey including active carbon cartridges can be taken out from access side. Easy to inspect and easy change of Active carbon cartridges.

Standard conformity:

Standard conformity of the equipment sections (modules) according to DIN EN 1886 is testified by the Test Report of RWTüV, dated 29.06.1995. Inconnection with this is a classification for the mechanical, acoustic, thermal and fire protecting parameters of the boxes:

Quality comparison of the boxes to Standard EN 1886 and RAL - GZ 652

The quality requirements of RAL - GZ 652 are fulfilled by the unit and in the most important requirements even surmounted.

Avoid condensation on surface:

When cold outside air is taken in and with very low cooling coil discharge temperature it may lead to a fall below the dew point at the corner points of the box and condensate may occur, when the relative humidity in the room where the unit stands is very high. If the unit is placed in the room that is to be airconditioned (e.g. Flat unit under the ceiling) it should be taken into consideration that an adequate exchange of air is guaranteed dur to keep room humidity low. As a measurement for equality of the surface temperature, the Heat bridge factor on one hand and the good heat insulation on the other hand, there is a high safety against condensation. Condensation can not be totally excluded under extreme thermal and hygiene conditions.

Mechanical safety:

Requirements of ISO 12499 are fulfilled as the access openings on the fan modules can be opened with a tool (Allen-wrench).

**Product line:
Standard and Flat Series**

Air handling unit selection diagram

Dimensions:

Height x Depth [mm]

350 x 650 **Flat 1**

350 x 750 **Flat 2**

350 x 1000 **Flat 3**

350 x 1350 **Flat 4**

400 x 1350 **Flat 5**

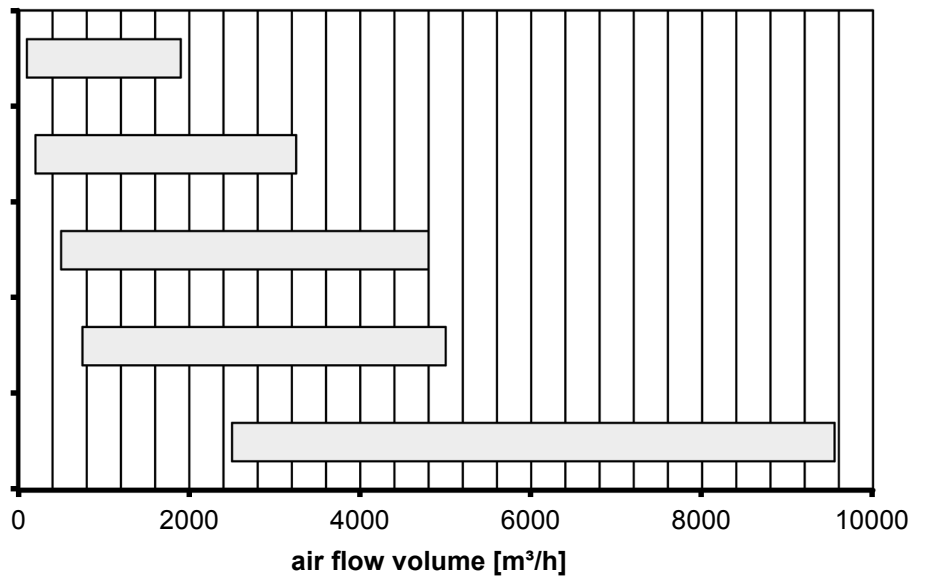

equipped with standard filter and filter monitoring

Dimensions:

Height x Depth [mm]

600 x 600 **Standard 1**

750 x 750 **Standard 2**

1000 x 1000 **Standard 3**

1350 x 1350 **Standard 4**

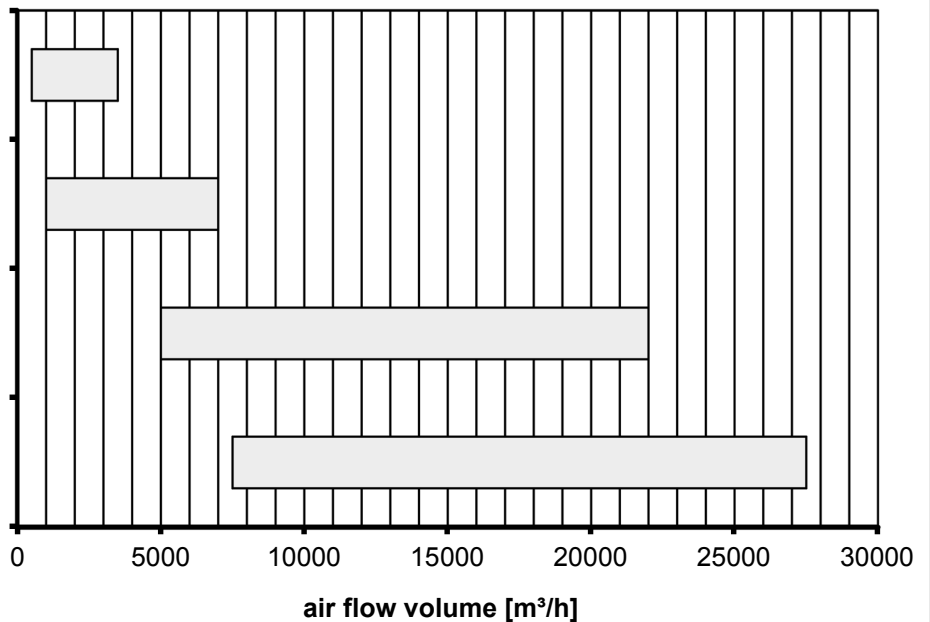

equipped with standard filter and filter monitoring

Product line:
Standard and Flat Series

Ventilator Unit
Static Pressure Regain

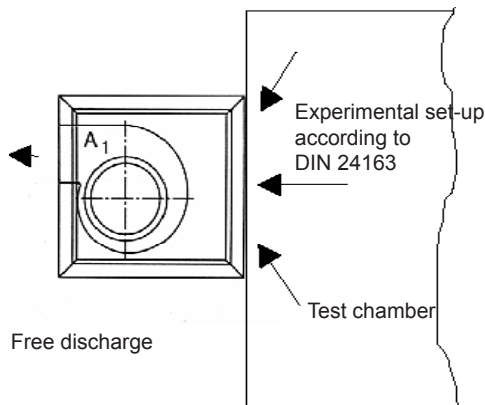

The Pressure/Air flow volume curve (see diagram of Ventilator Unit) is performance-tested with free inlet (without rear side panel) and free discharge (no duct connection)

Duct-connection on discharge side improves the flow conditions.

The energy, contained in the air due to velocity (dynamic pressure) on the discharge side of Ventilator Unit, can be partly transferred into static pressure by means of connected, expanded ducts (Pressure regain, see pictures).

This regain of static pressure is in addition to the regular static pressure available to overcome the resistance of the whole air conditioning system.

To obtain this increase in static pressure, diffusers designed to increase the cross-sectional area are required. (Fig.2: duct connection diffuser with enlarged cross section, Fig. 3: tapered diffuser to give an increase in the cross-sectional area).

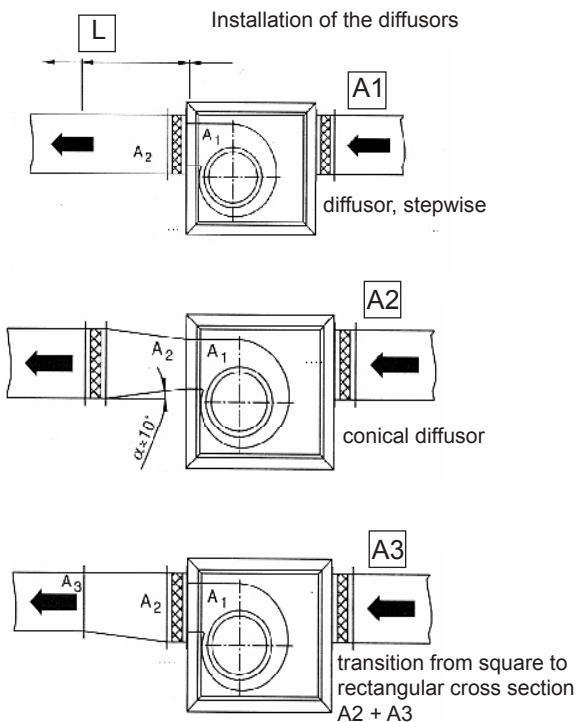

- A1 = Cross sectional area
- A2 = B = Anschlußquerschnitt
- A3 = cross section of standard connection size „B“ A3 = rectangular cross section (cross section A2 = A3)
- L = Length of diffuser

The optimum length of the tapered diffuser is determined by the angle (α).

The angle (α) should be $\leq 10^\circ$.

For duct connection (stepwise diffuser) A2 a minimal length L is necessary for the stated pressure regain. Indication of the minimal length: see performance datas of each fan unit.

In case of connection from square to rectangular A3 = A2 (see diagram 3), the pressure regain is identical to connection to A2 (standard connection size).

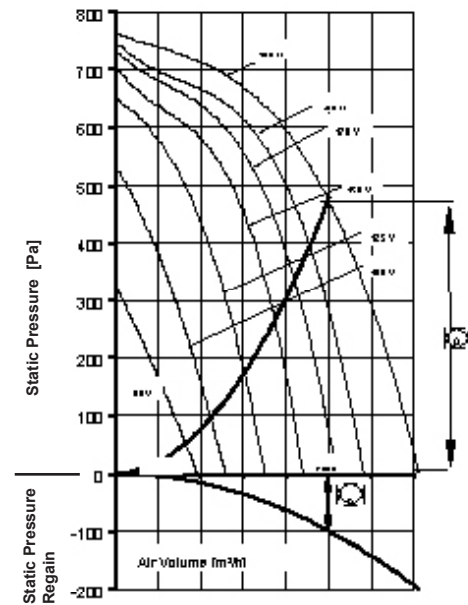

The pressure regain, by means of duct connection of appropriate length according to standard connection size „B“, is indicated underneath the axis of each pressure/volume diagram of Ventilator Units.

Example: **VN 202:**
 Air volume : VL = 5000 m³/h
 Static pressure (A) = 475 Pa
 Pressure regain by diffuser (B) = 100 Pa (acc. to curve)
 Total : = 575 Pa
 To overcome all resistances of the system, 575 Pa are max. available in total.

Using this method, the regain in pressure might be sufficient to select a smaller (cheaper) unit to be installed.

Product line:
Standard and Flat Series

Air Cooler Unit LK and LKV / LKR and LKRV
For cooling medium: chilled water (LK/LKV) or cooling agent (LKR/LKRV)

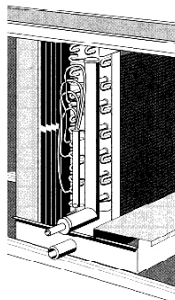

LKR Standard Series

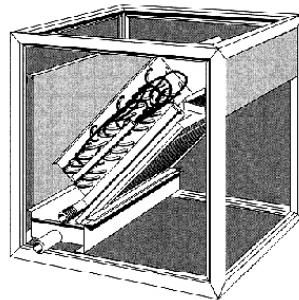

LKRV Standard Series

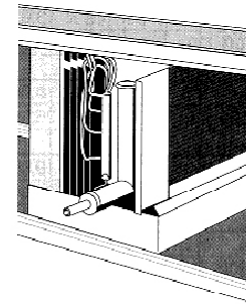

LKR Flat Series

Standard Series:

Cooling with water separator and drain tray, **pulled-in on rails**. Drain tray with lateral run-off plates for connection to **siphon** (not included). Cooling coil, water separator and drain tray can be pulled out separately for inspection and cleaning purposes.

Immediate condensate run-off by inclined plates. Drain tray out of anti-corrosion material. That new design features an up to 36,5% larger heat exchange surface.

Flat Series:

Cooling-element and water separator can be pulled-out sideways for inspection and cleaning purposes. Drain tray integrated into the bottom panel of the unit with **Condensate** by underneath pipe connection. Other details identical with Standard Series.

LK and LKV: Coils out of copper tube with fitted profiled aluminium fins, connection pipe out of copper, with steel screwed connection, male. Operating pressure max. 17 bar.

Design and performance according to German RAL-group-quality-standard: Air-flow velocity, Water pressure drop, Material and Function.

Air Cooler LK (horizontal air flow) with an high-efficiency **water separator**.

Air Cooler LKV only for air flow directions from the bottom to the top or horizontal air flow turned statical upwards. Equipped with a drop collector and run-off plate.

Pipe connection side = according to customers instructions, left (standard) or right hand side.

Direct Evaporator LKR and LKRV: Connections for cooling agent out of copper tube, **solder-hook terminated**.

In case of air coolers with direct expansion coolant, the cooling agent is introduced directly into the copper tube via a distributor. It is then extracted via the header in a vapourized form.

Coolers should be used only in connection with **pre-heaters** in front, or with an anti-freezing medium (glycol) added to the cooling medium (to avoid risk of freezing up!).

In case of using an antifreezing medium, a separate calculation of cooling performance is necessary!

When installing an Air Cooler Unit on the discharge side of a fan, a dummy section with an air distribution plate needs to be fitted between the Air Cooler and the fan discharge to enable appropriate air distribution.

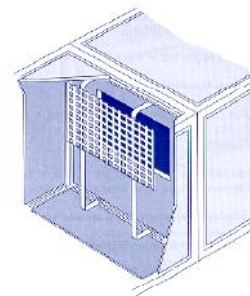

A **Siphon** needs to be fitted at site.

Nominal connection size: DN 40.

Dimensioning of the Siphon as follows (see also Mounting Instructions at page 11, fig. 3):

In case of negative pressure:

Measurement a in mm = neg. pressure in Pa / 10

Measurement b in mm = neg. pressure in Pa / 10

In case of positive pressure:

Measurement a in mm = pos. pressure in Pa / 10

When connecting **several Air-Coolers** to one condensate water pipe, a **siphon** has to be fitted to **each unit**. A Siphon installed on the **positive pressure side** must not be in a fix connection to a Siphon mounted to a **negative pressure side**. A **free intake into the collecting pipe** must be provided via admission hoppers.

Product line: **Air Heater Unit LW** for medium pump circulated water (LPHW)
Standard and Flat Series **Electric Air Heater Unit LE** for 400V/50Hz operating voltage

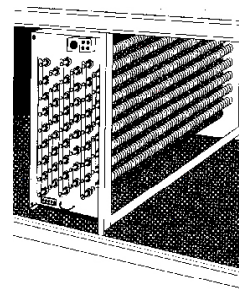
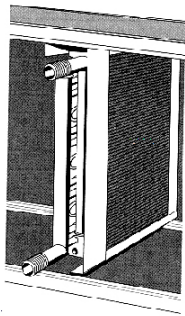

LW for medium pump circulated water (LPHW)

Mounting of coils:

Heating coil can be pulled in **on rails**.
 Coil to be **pulled out** sideways to service side. Simplified inspection and cleaning. Up to 21% **larger heat exchange surface**.

Flat Series:

Heating coil to be **pulled out sideways**, other details same as Standard Series.

Heating coil made of copper with bonded, high-performing aluminium fins. The pipes out of copper with steel screwed connection, male.

Operating pressure max. 17 bar.

Operating temperature up to 100°C.

Design and performance acc. to German RAL-group quality standard:

Air-flow velocity, water pressure drop, distance between laminars and material.

Connection side of pipes: in standard left hand.

The connection side can be changed from **left to right** by turning the complete Air Heater Unit.

The connection of pipe work (to be mounted at site) must be realised with **inverse flow**:

The outlet pipe of the heating coil is to be placed generally on the air-inlet side!

The thermal output is decreased in case of pipe connection in different way (parallel flow).

Frost station available as accessories.

Air Heater Units for Low-Pressure Steam available as special equipment an request.

Performance a data and pressure losses will be calculated on request !

LE for 400V/50Hz operating voltage

Standard and Flat Series

Heater element **mounted on rails**. Ready connect with integrated connection box. Heater element to be **pulled-out** sideways to the service side.

Simplified inspection and cleaning.

Simple electric supply (by customer).

In practice partly higher performance possible.

Air heating via gilled-pipes heating elements out of anti-corrosion **stainless steel**.

Heating coils out of high-temperature resistant Cr-Ni-material.

Safety design (wiring) acc. to RAL-group standard.

The Electric Heater Unit is equipped with a **temperature cut-out**, in standard.

The Electric Air Heater Unit has to be connected to other ACOVEN (fan unit) side via earthing strip (Protective Conductor).

The heater elements are connected in groups, ready for switching, in 2, 3 or 4 steps (depending on model and size).

The coils are connected ex factory for 400V/50 Hz 3-phase supply.

In order to avoid overheating, the heating coil is supplied and fitted with a temperature cut-out which is set to **90° C**. at the factory. The temperature-cut-out must always be installed in the upper area of unit, behind heating elements (in direction of air flow).

The electrical connection has to be made according to the wiring diagram. The fan and the Electric Air Heater Unit must be switched on at the same time. **A Time Relay accessory** is recommended to provide a **time lag of fan operation** (for 10 minutes) after switching-off the system.

In case of installation of the Electric Air Heater Unit on inlet side, the permissible air temperature of the fan must not be exceeded. Otherwise, the heater unit must be installed on the pressure side of the fan.

In case of fan speed control or other air volume control, a **minimum air volume** must be ensured to avoid overheating. Minimum Air Volume $V_{L\min}$:

$$V_{L\min} = Q \times 3600 / (60 - t_{ie})$$

t_{ie} : Airt temperature on-coil (°C)

Q: Thermal output of Electric Heater Unit (kW)

Product line: **Air Filter Unit KFS** with short or long pocket filter
Standard and Flat Series **Coarse Filter Unit GF** for the elimination of greasy and oily substances

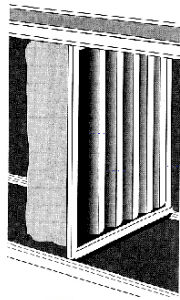

Air Filter Unit KFS for Standard Series

Standard filters mounted on rails.
 Pocket length: **195 and 600 mm**.
 Filter units to be **pulled-out** sideways to the service side.
 Easy inspection and easy exchange possible.
 Filter units: 195 mm long in G4(EU4)
 Filter units: 600 mm long in G4(EU4), F5(EU5), F7(EU7) and F9(EU9).
 Filters 600 mm long with **6 m² filter surface** (size 2, standard).
 Design and performance according to RAL-group-standards: large filter surfaces, filter classes appropriate for use.
 The filter material for the **filter classes** G4 and F5 is made of synthetic fibre material, F7 and F9 of a high-quality glass fibre.

Standard Series:

The requested side on which the filter should be pulled out, is the service side, left(standard) or right.
 If requested, filter frames for filter exchange towards dust-loaded air side are available. In this case, a dummy section needs to be fixed in front of the filter (for access).
Standard Filter mounted on rails.

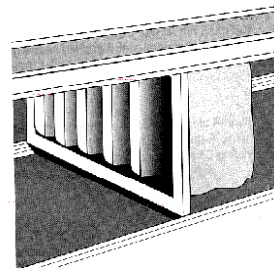

Air Filter Unit KFS for Flat Series

Bag length: **195 and 600 mm**.
 Filter units to be **pulled-out** downwards to the service side.
 Easy inspection and easy exchange.
 Filter classes same as for Standard Series.
 Filters 600 mm long with **4,9 m² filter surface** (size 2).
 When **installing the Filter on the fan discharge side**, a dummy section with an **air distribution plate** has to be installed between filter and fan outlet in order to reach an acceptable pressure drop.

Accessories:

For filter control, an **Inclined-Tube Pressure Gauge** or a **Differential Pressure Control** are available as accessories.
 For remote monitoring: **Differential Pressure Manometer** or **Inclined-Tube-Pressure Gauge** are available with a switch contact.

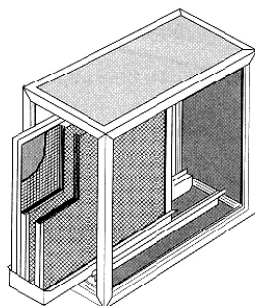

Coarse Filter Unit GF for Standard and Flat Series

Module for a 3-stage-filtration of dirty and **greasy air**.
 Filter elements out of multiple mesh structure and fibre mat pulled-in on rails.
 Separate **Drain Tray** in the side panel.
 Metal Filter and Fibre Mats can be **pulled-out to the service side** (Standard Series: sideways) (Flat Series: to the bottom).
Easy inspection, cleaning and exchange.
 Easy cleaning of the Drain Tray. Drain Tray to be dismantled to the bottom side. Drain Tray out of **aluminium**.
 Connection of a condensate pipe possible.
 Module for the filtration of dirty and **greasy air**.

Design:

Two metal filters of grid type structure fitted one behind the other, and a fibre mat in an exchange frame with supporting wire-net.
 All 3 Filter elements in plane filter design.
 Fibre mat in quality class G3.
 Metal Filters **out of anti-corrosion material**.
 The Fibre mat can be exchanged by **replacing the fibre mat**. The two metal filters can be washed cleaned in a washing machine or by high-pressure steam cleaners.
 The **air-flow direction** is determined to flow first through the two metal filters and then through the fibre mat.
 The oily substances are conducted by the fibre mat to the bottom side and collected in the Drain Tray.
 The saturation of the metal filters can be partly controlled by a Differential Pressure Manometer .
A continuous and regular inspection is absolutely necessary . The inspection intervals depend on the field of application of the unit and therefore need to be determined according the conditions at site.
 The Coarse Filter Unit GF can be used e.g. as first **Pre-Filter to an activated carbon filter**.
The service side is to be determined by the customer (standard side for standard series: left). Because of the fixed air-flow direction and the Drain tray, a turning of the Coarse Filter Module is not possible.

**Product line:
Standard and Flat Series**

Air Mixer Units LJ, LM and CLM
for AHU modules arranged on top of each other and in row

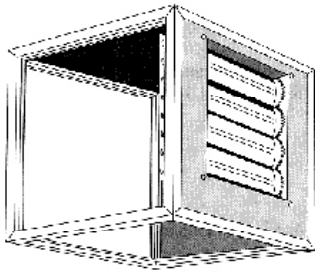

Standard Series LJ ...

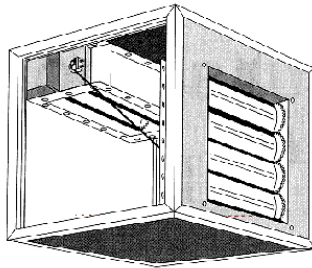

Standard Series LM ...

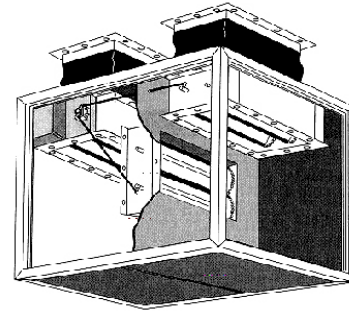

Standard Series CLM ...

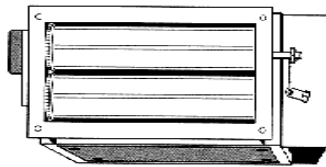

Flat Series LM ...

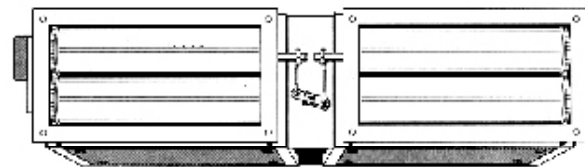

Flat Series CLM ...

Modules with mixing chamber for units arranged on top of each other.

Air Mixer Unit type LJ (with one damper) for mixing of outside air- and additional air flow.

Service side according to customers requirements. Access to the gears and servo-motors from the service side.

Air Mixer Unit type LJ is available with damper size „A“ (1) or damper size „B“ (1/2). (Type reference LJ-A (1) or LJ-B (1/2)).

Air Mixer Unit type LM (with 2 dampers) for supply and extract units arranged on top of each other are available with damper sizes „A“ (1) and damper sizes „B“ (1/2).

All dampers with U-frame in galvanized sheet metal. Laminars out of aluminium extruded section.

Dampers shafts in PVC-bearing bushes.

Air Mixer Unit CLM (with 3 dampers), for supply and extract units arranged in row.

Service side according to customers instruction. Access from the service side.

Delivered with three dampers 1/2 (size „B“).

All dampers with U-frame out of galvanized sheet metal. Laminars out of aluminium extruded section. Damper shafts in PVC-bearing bushes.

Fitting Actuators:

The dampers are in standard delivered to ensure motorized actuation via damper motors.

Our model range of BINAR-actuators is designed to fit optimal those requirements with ON/OFF and MODULATING models in 230 V as well as 24 V supply voltage.

Please contact us for more details.

If a manual damper operation is requested, please order manual lever as accessory.

Product line:
Standard and Flat Series

Activated Carbon Filter Unit ACKF

(for elimination of odours and toxic substances)

Dampers, Flexible Connections and Silencer duct Type

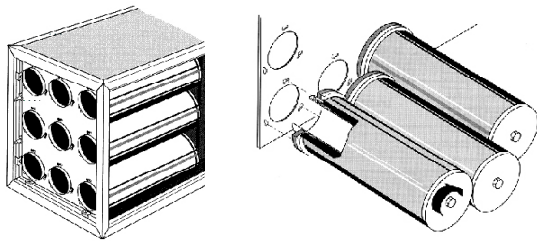

Activated Carbon Filter Unit:

Module to eliminate the emission of undesirable concentrations of odours substances to atmosphere, particularly to meet local authority regulations.

The number of cartridges is optimized according to the AHU sizes.

Casing frame mounted on rails, fitted with light weight **activated carbon filter cartridges**.

Casing frame including activated carbon filter cartridge to be **pulled-out** sideways to the **Service side** (Standard Series) and downwards (Flat Series). **Easy inspection and easy exchange** of the activated carbon filter.

The filter cartridge is made up of perforated galvanized inner and outer cylinder with a base and seal.

The cartridge class sealed due to the **bayonet fixing**. The two cylinders are filled with **activated carbon**, specially pressed in factory.

A gasket on the quick release lock seals the cartridge **air-tight** against the casing frame.

The **activated carbon filter cartridges** have to be protected from greasy and oily substances by appropriate **pre-filters**.

In case of **oily air** conditions (e.g. in kitchens), a Coarse Filter Unit GF and a Bag Filter Unit KFS with filter class F7, must be installed in front of the Activated Carbon Filter Unit (in air-flow direction).

The Activated Carbon Filter Unit should be installed only on the inlet side of the fan. If the unit must be positioned on the **pressure side**, a dummy section with a **diffuser plate** must be installed between the fan-discharge and filter unit.

The **lifetime** of the activated carbon depends on the quality of the pre-filtration and on the concentration and kind of odors.

Following max. air-conditions are valid for operation, storage and transport of activated carbon filters:

Air-humidity: max. 70% rel. humidity

Temperature: max. 50 °C

Dampers:

U-Frame made of galvanized sheet metal, with frame elongated holes to fit flexible connections as well as on usual ducts. Hollow profile laminars out of aluminium extruded sections. Shafts in PVC-bearing bushes.

Standard Series: Dampers available in 2 sizes (for each FISCHBACH AHU size):

- size „A“ (big, 1) - size „B“ (small, 1/2)

Flat Series: Dampers available in size „A“ (1).

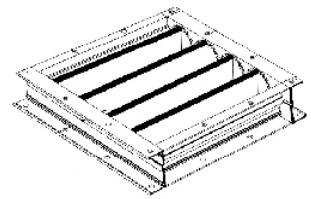

Flexible Connection:

Galvanized angle frame on both sides. Frame with elongated holes to fit ducts, dampers or modules. Material: Polyester with vinyl coating. According to specifications of customers, available as well in other materials on request.

Standard Series: Flexible Connections available in 2 sizes (for each FISCHBACH AHU size):

- size „A“ (big, 1) - size „B“ (small, 1/2)

Flat Series: Flexible Connections available (for each FISCHBACH AHU size in size „A“ (big, 1)

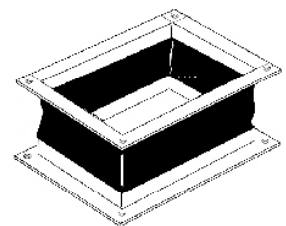

Silencer duct Type.

Silencer duct type are available as accessories. Silencer are

designed especially to fit the performance range of

FISCHBACH-Products with regard to attenuation and dimensions. The attenuation performance can be varied by aggregation of the necessary number of modules each 500 mm long.

Silencer modules with lengths of: 850mm, 1350 mm and 1750 mm, including streaming chamber. Attenuator inserts in Air-handling-unit box.

Casing of the Silencers out of galvanized sheet metal, with angle profiles on both sides for direct, easy mounting to FISCHBACH-modules, to following silencer or the duct. Attenuator inserts meet the German-RAL-group-quality-standard and has been developed especially for the use in Air Handling Units. Wide band attenuation from 250 to 1000 Hz. The attenuator inserts act partially as resonance chambers and partially as absorbing chambers in order to get optimal attenuation results. The attenuator inserts have a coating of glass fibre - abrasion proof up to 20 m/s Absorption material out of mineral fibre date, non-inflammable according to DIN 4102.

