

**Series: AIR PURIFIER LR**  
with FISCHBACH-Compact-Fan  
and FISCHBACH - EC-MOTOR

**FISCHBACH**  
Luft- und Ventilatorentechnik GmbH

**Type: LR 101** with DS6-740/EM35

**ERP KONFORM**

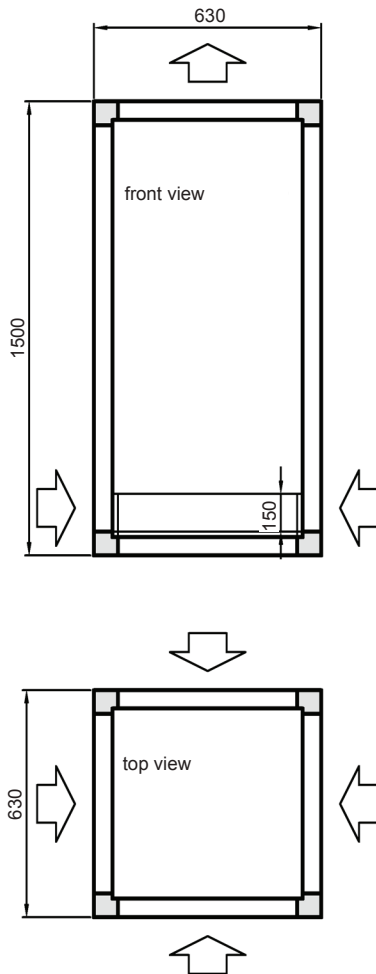

**manufacturer:**  
Fischbach Luft- und Ventilatorentechnik GmbH  
Am Hellerberg 22-24  
D-57290 Neunkirchen  
phone: ++49(0)2735/777-0  
telefax: ++49(0)2735/770-625  
internet: www.fischbach-luft.de  
email: info@fischbach-luft.de

**Technical Data**

weight:	(kg)	165
material housing:		aluminum/plastic steel, galvanized
material impeller:		steel, galvanized
direction of rotation:		left
motor protection class:		IP 65
insulation class:		F
motor protection:		thermal contact

**connection plan\*  
FFU-EC 230**

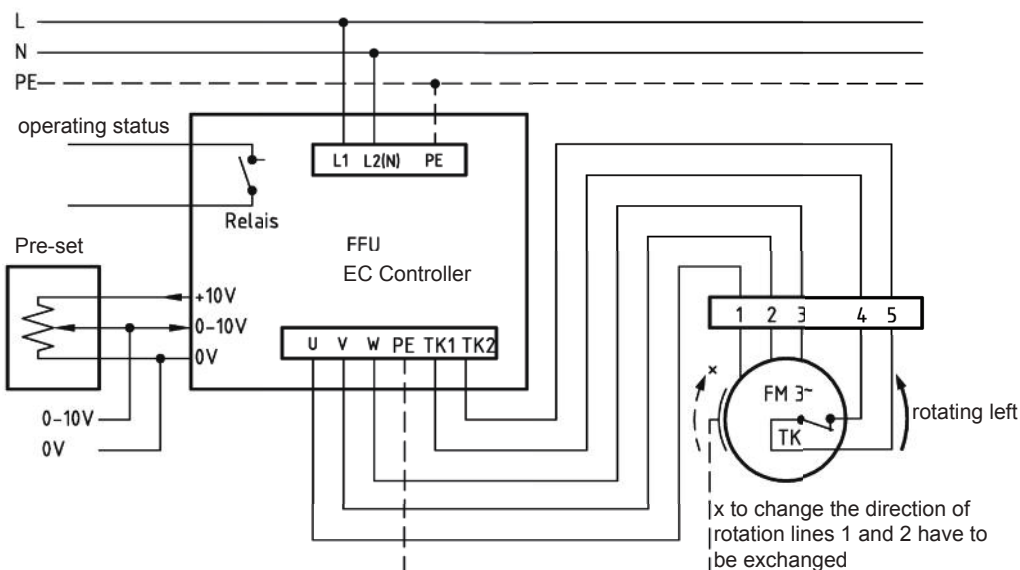

\* Connection only according to the enclosed technical documentation.

the silent one

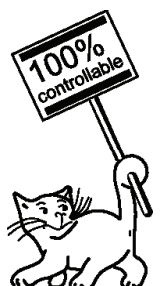

**Series: AIR PURIFIER LR**  
with FISCHBACH-Compact-Fan  
and FISCHBACH - EC-MOTOR

**FISCHBACH**  
Luft- und Ventilatorentechnik GmbH

**Type: LR 101 with DS6-740/EM35**

ErP 2013 2015 2018 x

**Performance data**

main voltage:	(V)	230 (1~)
frequency:	(Hz)	50
current max.:	(A)	4,0
power input max.:	(kW)	0,58
air flow volume max.:	(m³/h)	1880
statical pressure max.:	(Pa)	458
speed max.:	(rpm)	1350
max. air flow temperature	(°C)	80
max. ambient temperature	(°C)	30
capacitor:	(µF)	-

**ErP-Data fan:**

total efficiency fan ( $\eta_e$ ):	(%)	47,0
installation category:		A
efficiency category:		static
efficiency grade: N	(%)	42
target efficiency ( $\eta_{target}$ ):	(%)	39,4
speed controller		yes
year of manufacturing		since 2015
manufacturer: Fischbach Luft- und Ventilatorentechnik GmbH D-57290 Neunkirchen / HRB 5804 Siegen		
order no. (left)		58840030
power input:	(kW)	0,66
air flow volume:	(m³/h)	2226
statical pressure:	(Pa)	456
speed:	(rpm)	1350
specific ratio:		1
disassembling/recycling/disposal: see page decommission		
installation/operation/maintenance: see operating and mounting instructions		
measurement for determination of efficiency without additional items		

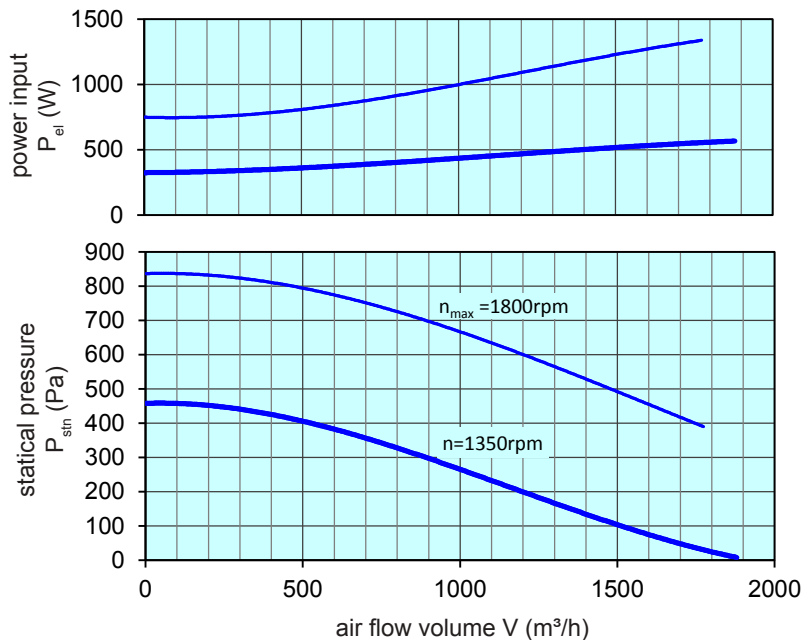

control with	type	order-Nr.
FISCHBACH-frequency converter	FFU1-21-2.2	63720
FISCHBACH-Pre-set 0-10V (optional accessories)	FS 10	69460

Subject to change! / Technical documentation according to page: **General information**

**Type: LR 101 with DS6-740/EM35**

**pst-V - diagram**

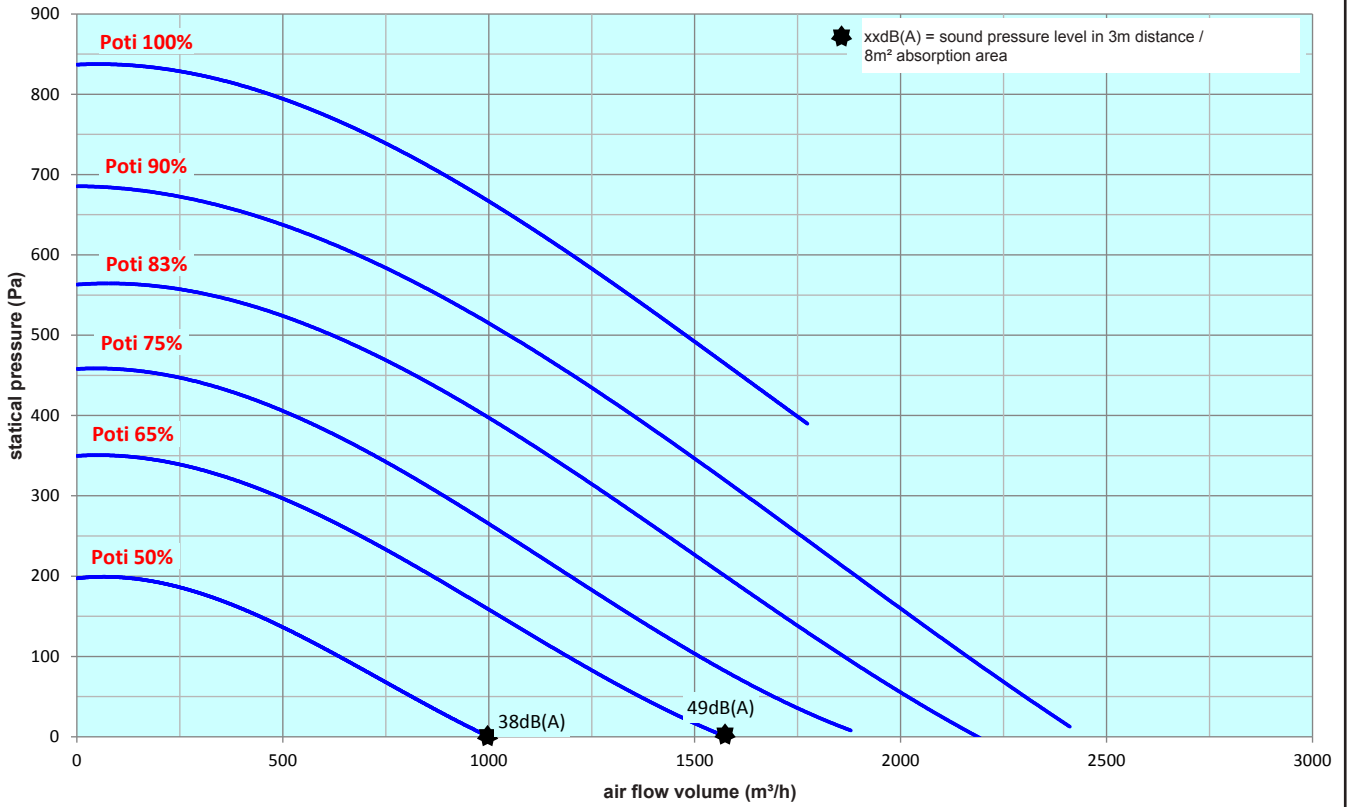

**air flow volume at filter clean - contaminated**

