

Series: AIR PURIFIER LR
with FISCHBACH-Compact-Fan
and FISCHBACH - disc-rotor-motor

FISCHBACH

Luft- und Ventilatorentechnik GmbH

Type: LRF 100 with D270/E1

ERP KONFORM

CE -conform

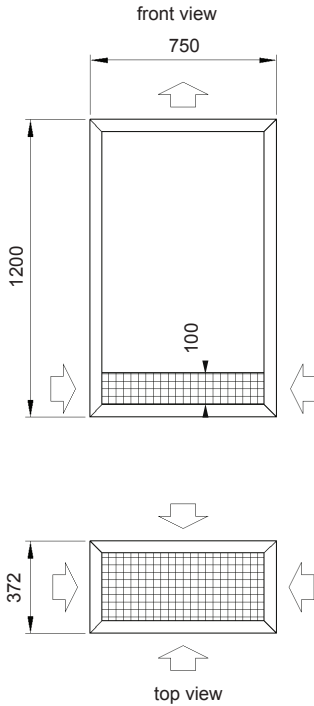

manufacturer:
Fischbach Luft- und Ventilatorentechnik GmbH
Am Hellerberg 22-24
D-57290 Neunkirchen
phone: ++49(0)2735/777-0
telefax: ++49(0)2735/770-625
internet: www.fischbach-luft.de
email: info@fischbach-luft.de

Technical Data

weight:	(kg)	80
material housing:	aluminum	
	steel, galvanized	
material impeller:	steel, galvanized	
direction of rotation:	left	
motor protection class:	IP 65	
insulation class:	F	
motor protection:	thermal contact	

connection plan*
F-AC 0.5

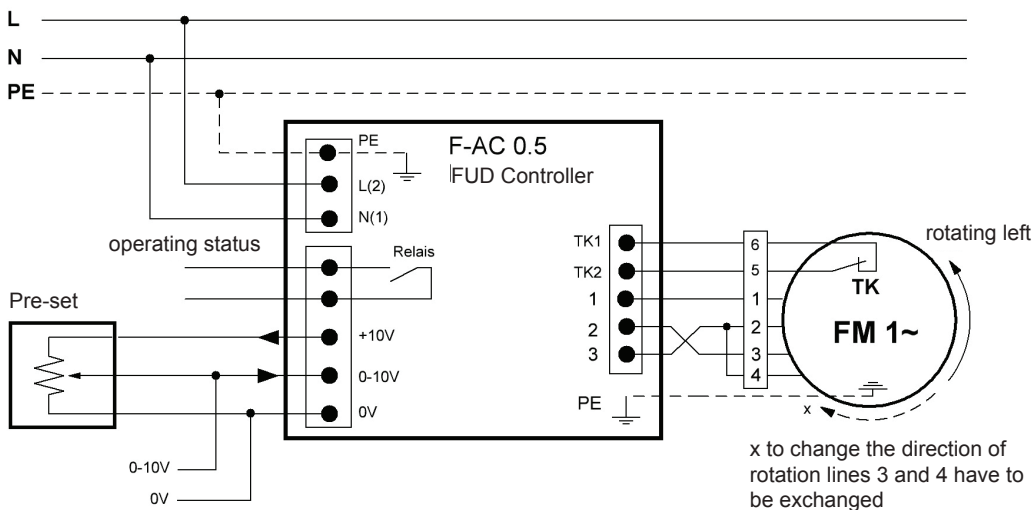

x to change the direction of rotation lines 3 and 4 have to be exchanged



the silent one

* Connection only according to the enclosed technical documentation.

Series: AIR PURIFIER LR
with FISCHBACH-Compact-Fan
and FISCHBACH - disc-rotor-motor

FISCHBACH
Luft- und Ventilatorentechnik GmbH

Type: LRF 100 with D270/E1

ErP 2013 2015 2018 x

Performance data

main voltage:	(V)	230 (1~)
frequency:	(Hz)	50
current max.:	(A)	0,82
power input max.:	(kW)	0,94
air flow volume max.:	(m³/h)	350
statical pressure max.:	(Pa)	125
speed max.:	(rpm)	1120
max. air flow temperature	(°C)	80
max. ambient temperature	(°C)	30
capacitor:	(µF)	-

ErP-Data fan:

total efficiency fan (η_e):	(%)	30,8
installation category:		A
efficiency category:		static
efficiency grade: N	(%)	42
target efficiency (η_{target}):	(%)	30,8
speed controller		yes
year of manufacturing		since 2015
manufacturer: Fischbach Luft- und Ventilatorentechnik GmbH D-57290 Neunkirchen / HRB 5804 Siegen		
order no. (left)		58840020
power input:	(kW)	165
air flow volume:	(m³/h)	578
statical pressure:	(Pa)	276
speed:	(rpm)	1614
specific ratio:		1
disassembling/recycling/disposal: see page decommission		
installation/operation/maintenance: see operating and mounting instructions		
measurement for determination of efficiency without additional items		

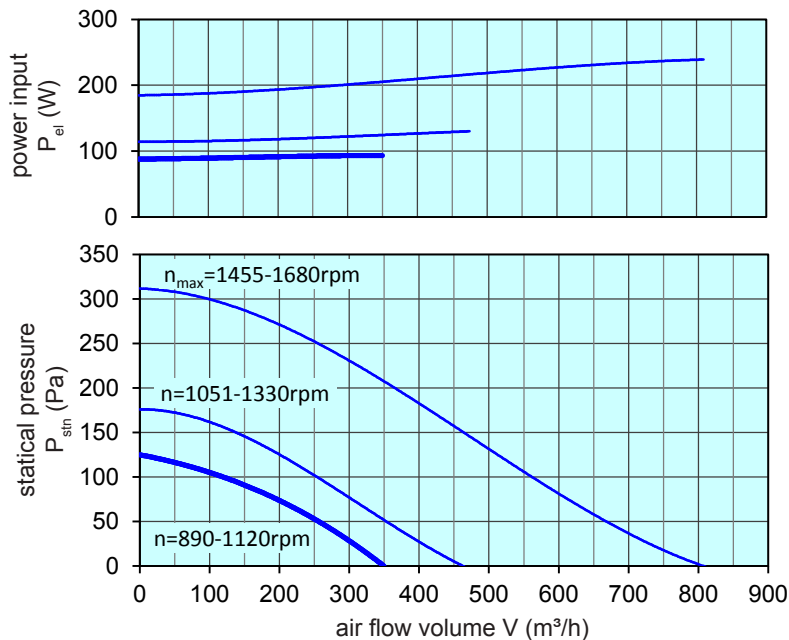

control with	type	order-Nr.
FISCHBACH-frequency converter	F-AC 0.5	63005
FISCHBACH-Pre-set 0-10V (optional accessories)	FS 10	69460

Subject to change! / Technical documentation according to page: **General information**

Type: LRF 100 with D270/E1

pst-V - diagram

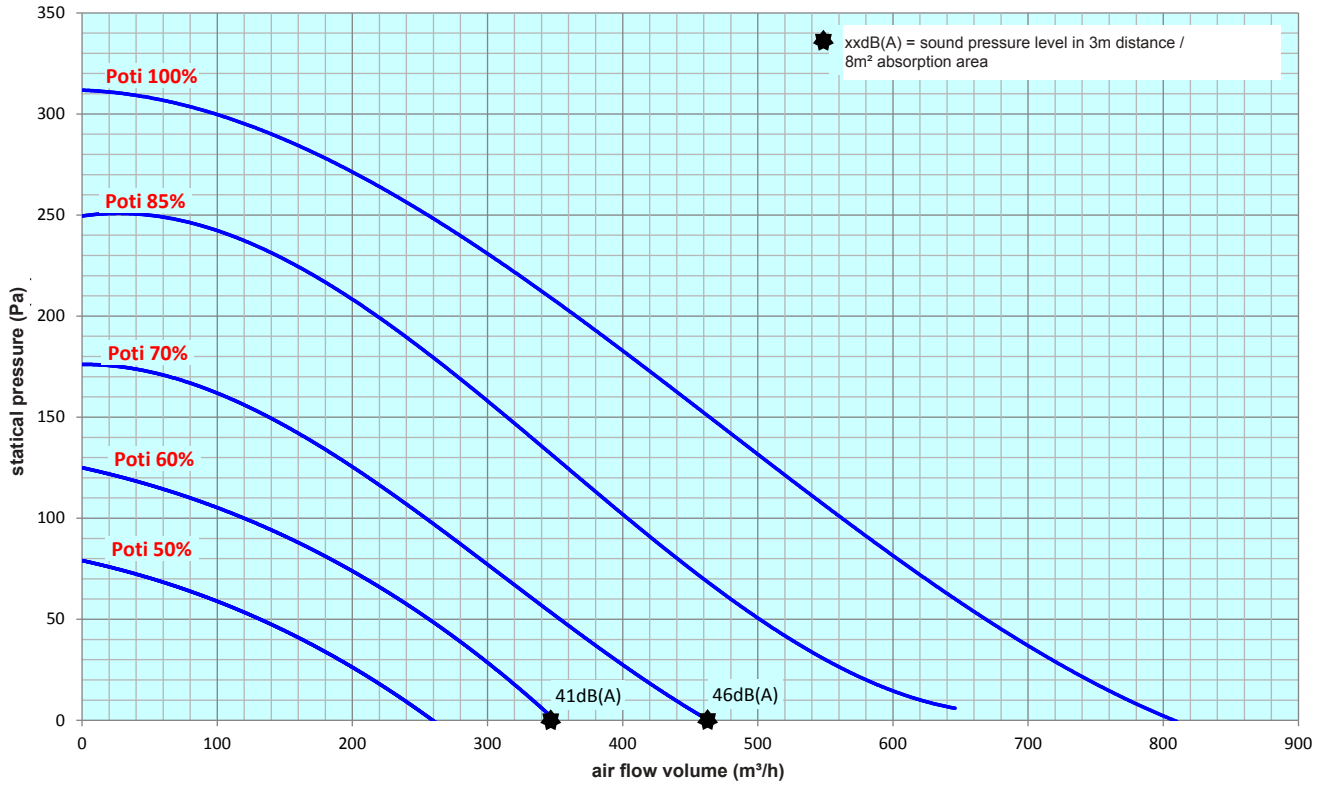

air flow volume at filter clean - contaminated

