

Series: EASY-BOX FEB
 with Freewheeling impeller with
 backward curved blades **EC-MOTOR**

FISCHBACH

Luft- und Ventilatorentechnik GmbH

Type: FEB400/EM35

ERP KONFORM



CE -conform

Forgalmazó:
 Oxyrna Systems Kft.
 3433 Nyékládháza, Ady Endre u. 49/A

phone: +36 (30) 665-5982
 internet: www.fischbach-air.hu
 email: oxyrna@oxyrna.hu

Technical Data

weight:	(kg)	27,5
material housing:		aluminum/plastic steel, galvanized
material impeller:		steel, galvanized
direction of rotation:		left
motor protection class:		IP 65
insulation class:		F
motor protection:		thermal contact

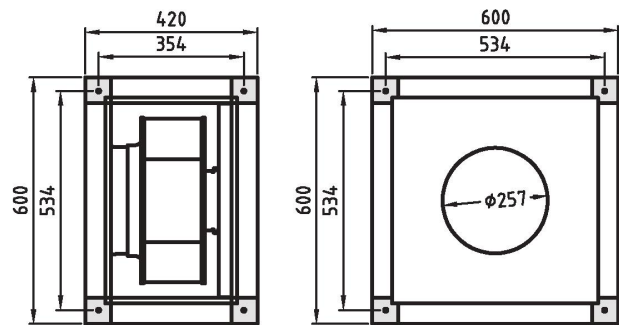

**connection plan
 FFU-EC 230**

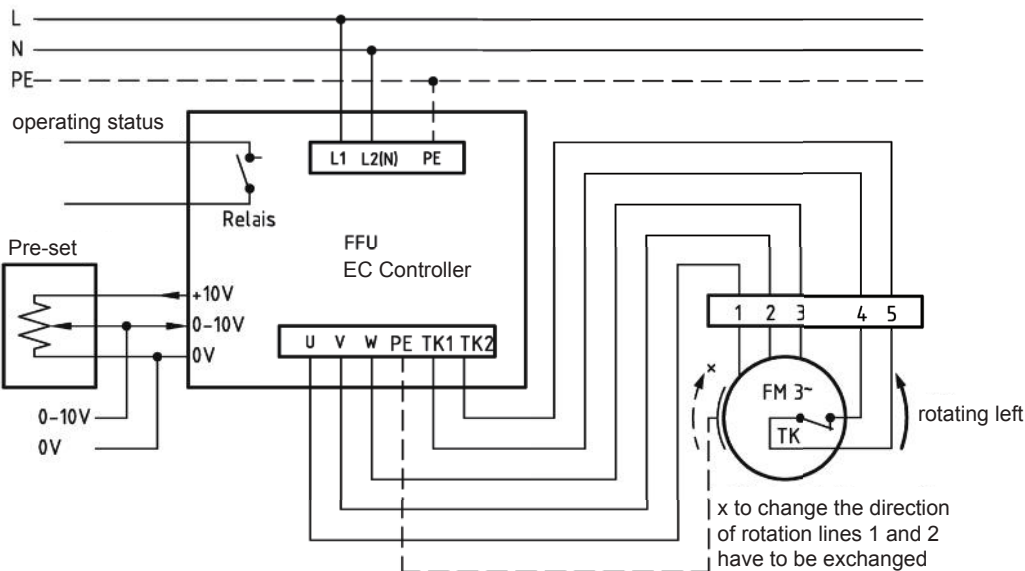

* Connection only according to the enclosed technical documentation.

the silent one

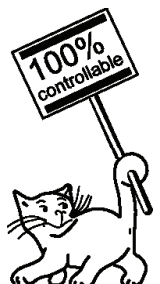

Series: EASY-BOX FEB
 with Freewheeling impeller with
 backward curved blades **EC-MOTOR**

FISCHBACH
 Luft- und Ventilatorentechnik GmbH

Type: FEB400/EM35

ErP 2013 2015 2018 x

Performance data

main voltage:	(V)	230 (1~)
frequency:	(Hz)	50
current max.:	(A)	4,1
power input max.:	(kW)	0,64
air flow volume max.:	(m³/h)	4600
statical pressure max.:	(Pa)	543
speed max.:	(rpm)	1500
max. air flow temperature	(°C)	80
max. ambient temperature	(°C)	30
capacitor:	(µF)	-

ErP-Data:

total efficiency fan (η_e):	(%)	55,9
installation category:		A
efficiency category:		static
efficiency grade: N	(%)	62
target efficiency (η_{target}):	(%)	49,3
speed controller		yes
year of manufacturing		since 2015
manufacturer:	Fischbach Luft- und Ventilatorentechnik GmbH D-57290 Neunkirchen / HRB 5804 Siegen	
order no. (left)		18182610
power input:	(kW)	0,62
air flow volume:	(m³/h)	2505
statical pressure:	(Pa)	452
speed:	(rpm)	1500
specific ratio:		1
disassembling/recycling/disposal: see page decommission		
installation/operation/maintenance: see operating and mounting instructions		
measurement for determination of efficiency without additional items		

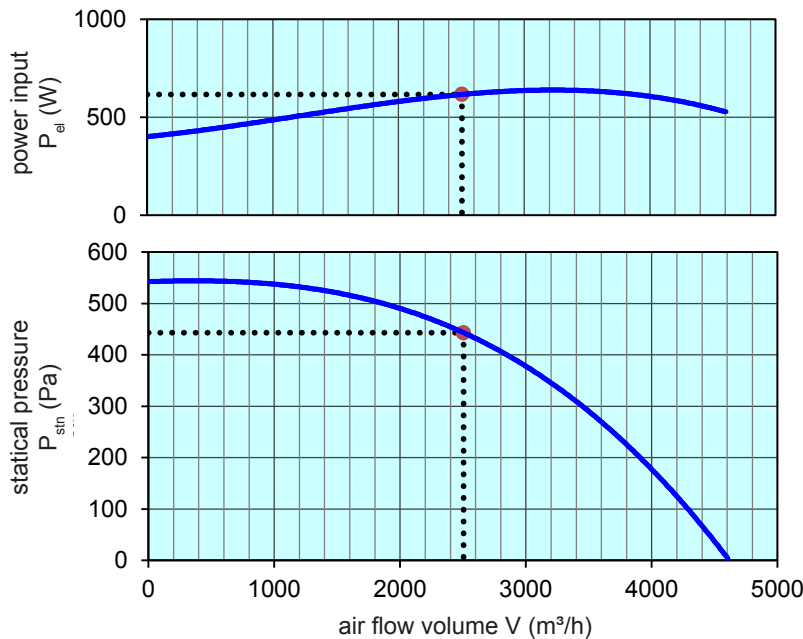

control with	type	order-Nr.
FISCHBACH-EC-controller	FFU1-21-2,2	63720
FISCHBACH-Pre-set 0-10V (optional accessories)	FS 10	69460

Technical documentation according to page: **General information**