

**Series: MULTI-EXHAUST-UNIT FMB**  
 with Freewheeling impeller with  
 backward curved blades **EC-MOTOR**

**FISCHBACH**

Luft- und Ventilatorentechnik GmbH

**Type: FMB2/2-450/DM500**

**ERP KONFORM**



**Forgalmazó:**  
 Oxyma Systems Kft.  
 3433 Nyékládháza, Ady Endre u. 49/A

phone: +36 (30) 665-5982  
 internet: www.fischbach-air.hu  
 email: oxyma@oxyma.hu

**Technical Data**

weight:	(kg)	37
material housing:		aluminum/plastic steel, galvanized
material impeller:		steel, galvanized
direction of rotation:		left/right
motor-protection class:		IP 65
insulation class:		F
motor protection:		thermal contact

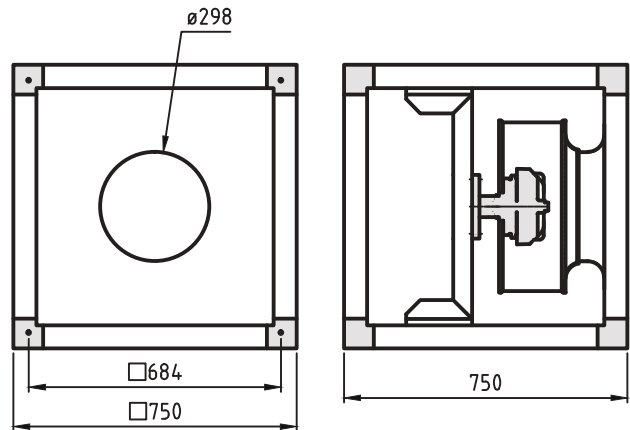

**connection plan\*  
 FFU-EC 400**

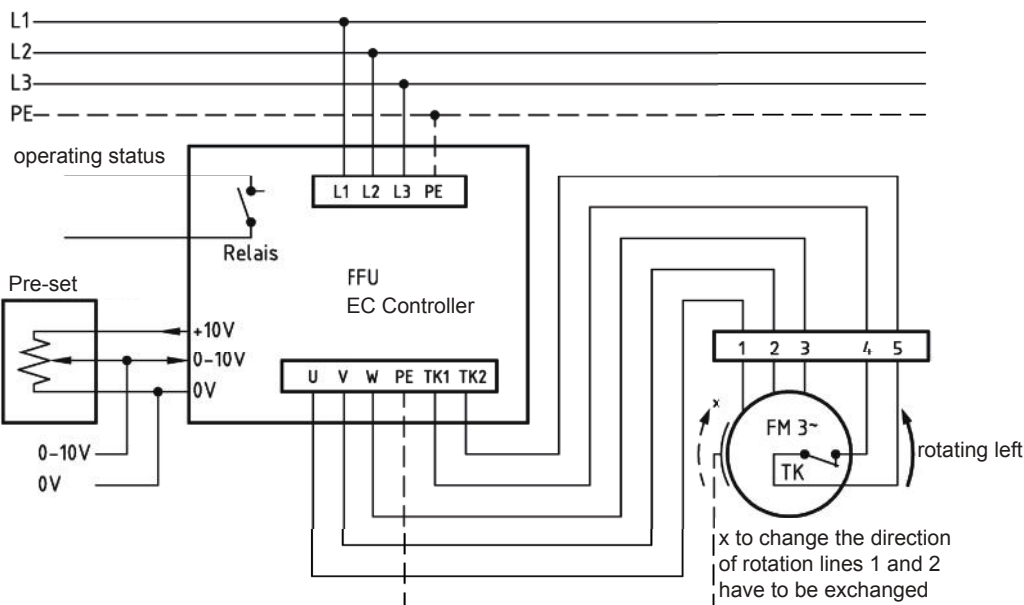

\* Connection only according to the enclosed technical documentation.

the silent one

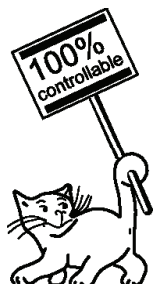

**Series: MULTI-EXHAUST-UNIT FMB**  
 with Freewheeling impeller with  
 backward curved blades **EC-MOTOR**

**FISCHBACH**  
 Luft- und Ventilatorentechnik GmbH

**Type: FMB2/2-450/DM500**

Erp 2013 2015 2018 x

**Performance data**

main voltage:	(V)	400 (3~)
frequency:	(Hz)	50
current max.:	(A)	2,3
power input max.:	(kW)	1,0
air flow volume max.:	(m³/h)	6650
statical pressure max.:	(Pa)	627
speed max.:	(rpm)	1500
supply air temperature:	(°C)	-25... +60
capacitor:	(µF)	-

**ErP-Data:**

total efficiency fan ( $\eta_e$ ):	(%)	63,4
installation category:		A
efficiency category:		static
efficiency grade: N	(%)	62
target efficiency ( $\eta_{target}$ ):	(%)	51,4
speed controller		yes
year of manufacturing		since 2015
manufacturer: Fischbach Luft- und Ventilatorentechnik GmbH D-57290 Neunkirchen / HRB 5804 Siegen		
order no. (left)		18125030
power input:	(kW)	0,97
air flow volume:	(m³/h)	3961
statical pressure:	(Pa)	513
speed:	(rpm)	1500
specific ratio:		1
disassembling/recycling/disposal: see page decommission		
installation/operation/maintenance: see operating and mounting instructions		
measurement for determination of efficiency without additional items		

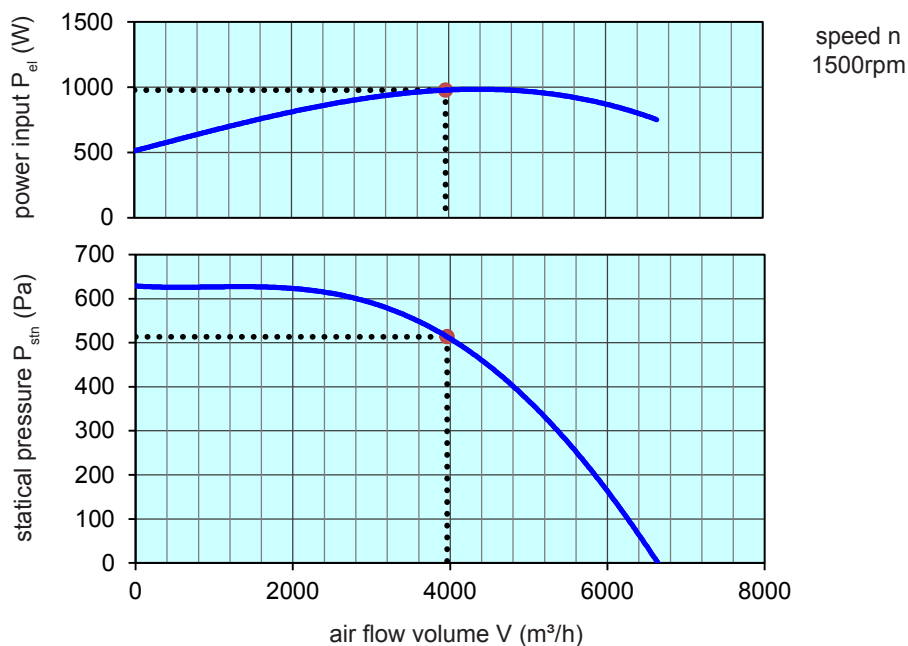

control with	type	order-Nr.
FISCHBACH-frequency-converter	FFU3-21-1.5	63740
FISCHBACH-Pre-set 0-10V (optional accessories)	FS 10	69460

Technical documentation according to page: **General information**