

**Series: FREEWHEELING IMPELLER with
INSTALLATION FRAME FLRE**
with backward curved blades

FISCHBACH

Luft- und Ventilatorentechnik GmbH

Type: FLRE355/E15

ERP KONFORM



CE -conform

Forgalmazó:
Oxyma Systems Kft.
3433 Nyékládháza, Ady Endre u. 49/A

phone: +36 (30) 665-5982
internet: www.fischbach-air.hu
email: oxyma@oxyma.hu

Technical Data

weight:	(kg)	18
material housing:	steel, galvanized	
material impeller:	steel, galvanized	
direction of rotation:	left/right	
motor protection class:	IP 65	
insulation class:	F	
motor protection:	thermal contact	

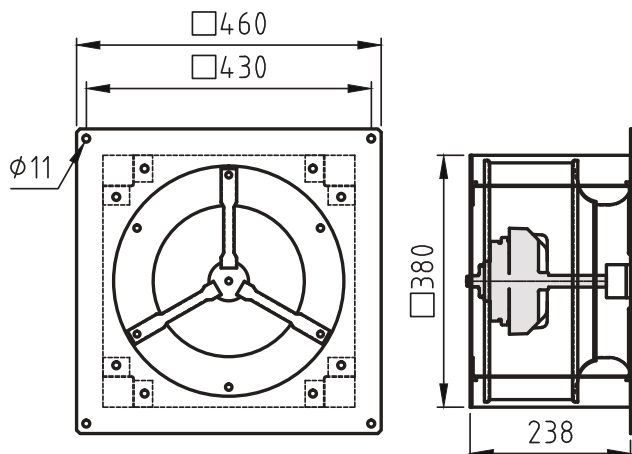

connection plan
0.11-1 r.

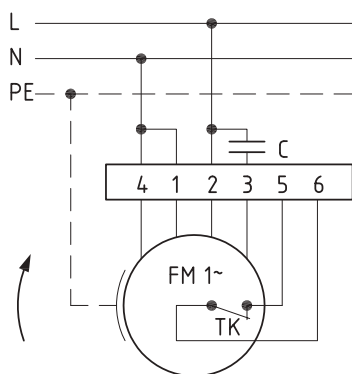

rotating right

connection plan
0.11-1 l.

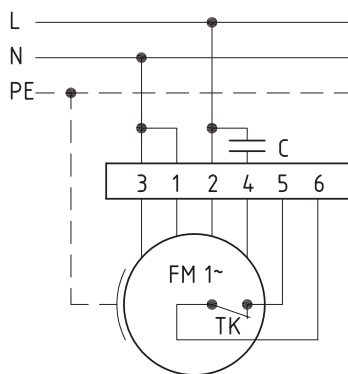

rotating left

100%
controllable



the silent one

**Series: FREEWHEELING IMPELLER with
INSTALLATION FRAME FLRE**
with backward curved blades

FISCHBACH
Luft- und Ventilatorentechnik GmbH

Type: FLRE355/E15

Erp 2013 2015 x 2018

Performance data

main voltage:	(V)	230 (1~)
frequency:	(Hz)	50
current max.:	(A)	1,5
power input max.:	(kW)	0,3
air flow volume max.:	(m³/h)	2964
statical pressure max.:	(Pa)	367
speed max.:	(rpm)	1384
supply air temperature:	(°C)	-25...+60
capacitor:	(µF)	8

ErP-Data:

total efficiency fan (η_e):	(%)	45,6
installation category:		A
efficiency category:		static
efficiency grade: N	(%)	62
target efficiency (η_{target}):	(%)	45,5
speed controller		no
year of manufacturing		since 2015
manufacturer: Fischbach Luft- und Ventilatorentechnik GmbH D-57290 Neunkirchen / HRB 5804 Siegen		
order no. (left)		18027010
power input:	(kW)	0,268
air flow volume:	(m³/h)	1656
statical pressure:	(Pa)	265
speed:	(rpm)	1296
specific ratio:		1
disassembling/recycling/disposal: see page decommission		
installation/operation/maintenance: see operating and mounting instructions		
measurement for determination of efficiency without additional items		

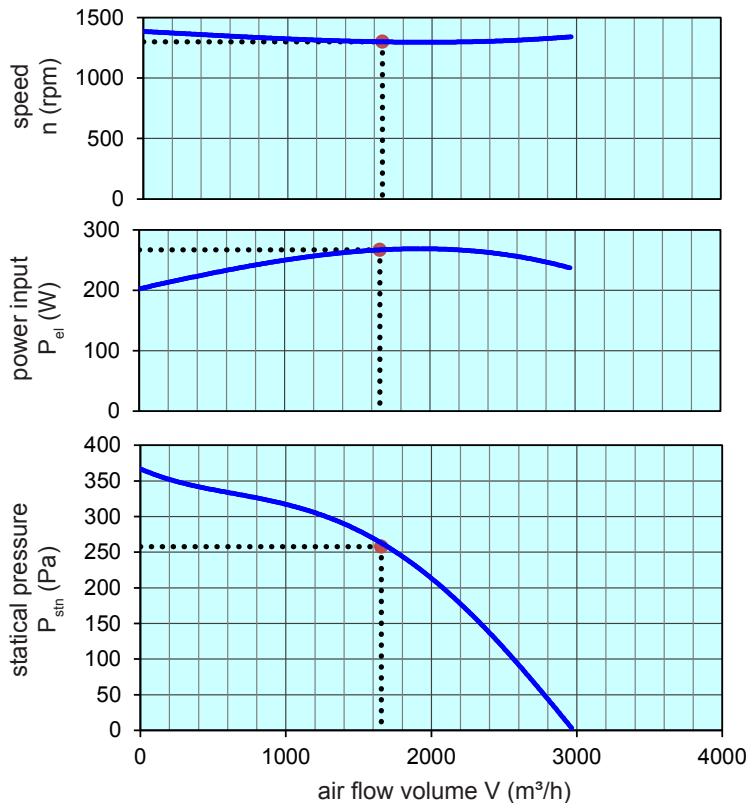

Voltage Control	type	order-no.
FISCHBACH-Speed-Controller, stepless	FDR 32	6162
FISCHBACH-Speed-Controller, stepwise	FDR 420	6201
FISCHBACH-Automatic-Control	FRA 32	6251
FISCHBACH-Control-Unit	FRE 6	63001

Technical documentation according to page: **General information**