

Series: MULTI-EXHAUST-UNIT FMB

with Freewheeling impeller with backward curved blades

FISCHBACH

Luft- und Ventilatorentechnik GmbH

Type: FMB2/1-400/E25

ERP KONFORM



Forgalmazó:

Oxyma Systems Kft.
3433 Nyékládháza, Ady Endre u. 49/A

phone: +36 (30) 665-5982
internet: www.fischbach-air.hu
email: oxyma@oxyma.hu

Technical Data

weight:	(kg)	27,5
material housing:		aluminum/plastic steel, galvanized
material impeller:		steel, galvanized
direction of rotation:		left/right
motor protection class:		IP 65
insulation class:		F
motor protection:		thermal contact

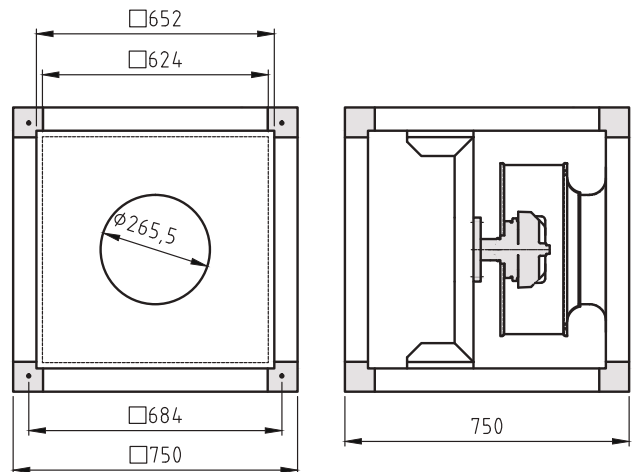

connection plan
0.11-1 r.

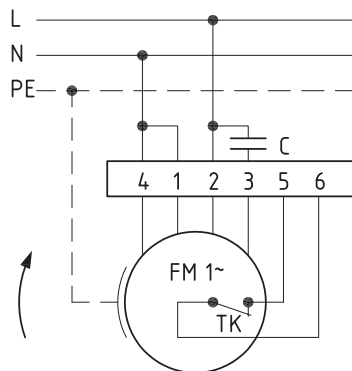

rotating right

connection plan
0.11-1 l.

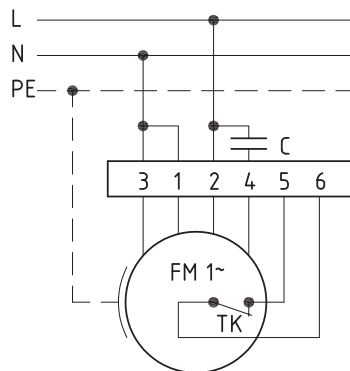

rotating left

the silent one



Series: MULTI-EXHAUST-UNIT FMB

with Freewheeling impeller with backward curved blades

FISCHBACH

Luft- und Ventilatorentechnik GmbH

Type: FMB2/1-400/E25

ErP 2013 2015 2018 x

Performance data

main voltage:	(V)	230 (1~)
frequency:	(Hz)	50
current max.:	(A)	2,1
power input max.:	(kW)	0,45
air flow volume max.:	(m³/h)	4240
statical pressure max.:	(Pa)	432
speed max.:	(rpm)	1389
supply air temperature:	(°C)	-25...+60
capacitor:	(µF)	12

ErP-Data:

total efficiency fan (η_e):	(%)	47,9
installation category:		A
efficiency category:		static
efficiency grade: N	(%)	62
target efficiency (η_{target}):	(%)	47,7
speed controller		no
year of manufacturing		since 2015
manufacturer:	Fischbach Luft- und Ventilatorentechnik GmbH D-57290 Neunkirchen / HRB 5804 Siegen	
order no. (left)		18025020
power input:	(kW)	0,44
air flow volume:	(m³/h)	2210
statical pressure:	(Pa)	343
speed:	(rpm)	1280
specific ratio:		1
disassembling/recycling/disposal: see page decommission		
installation/operation/maintenance: see operating and mounting instructions		
measurement for determination of efficiency without additional items		

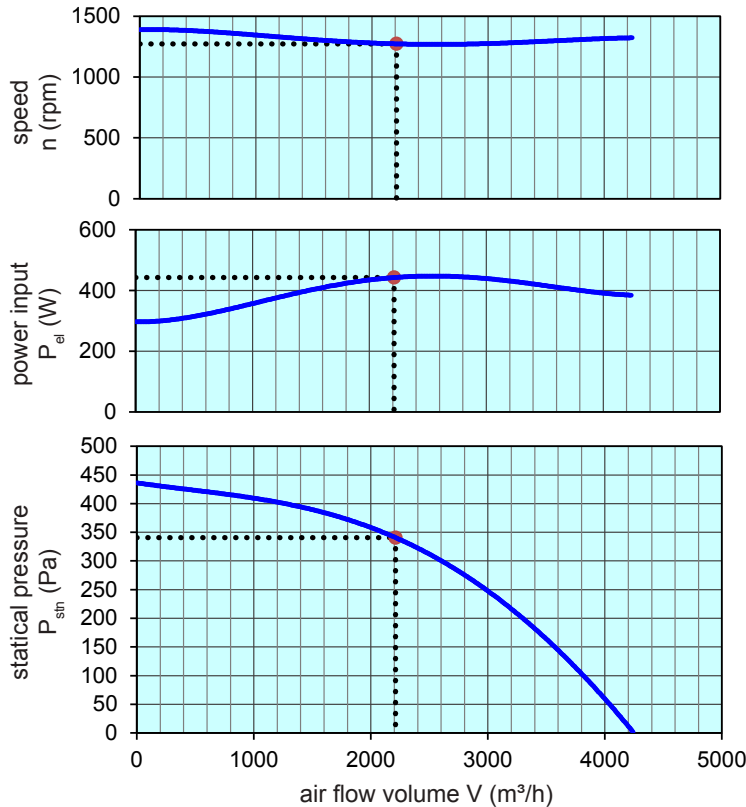

Measurement was carried out without casing!

Voltage Control	type	order-no.
FISCHBACH-Speed-Controller, stepless	FDR 55	6163
FISCHBACH-Speed-Controller, stepwise	FDR 420	6201
FISCHBACH-Automatic-Control	FRA 55	6252
FISCHBACH-Control-Unit Frequency-Converter	FRE 6	63001

Technical documentation according to page: **General information**