

Series: THERMAL-EXHAUST-UNIT FMBT-EC
 with Freewheeling impeller with
 backward curved blades **EC-MOTOR**

FISCHBACH

Luft- und Ventilatorentechnik GmbH

Type: FMBT-EC-40/500/DM1

ERP KONFORM



Forgalmazó:
 Oxyma Systems Kft.
 3433 Nyékládháza, Ady Endre u. 49/A

phone: +36 (30) 665-5982
 internet: www.fischbach-air.hu
 email: oxyma@oxyma.hu

Technical Data

weight:	(kg)	42
material housing:	aluminum/plastic steel, galvanized	
material impeller:	steel, galvanized	
direction of rotation:	left/right	
motor-protection class:	IP 65	
insulation class:	F	
motor protection:	thermal contact	

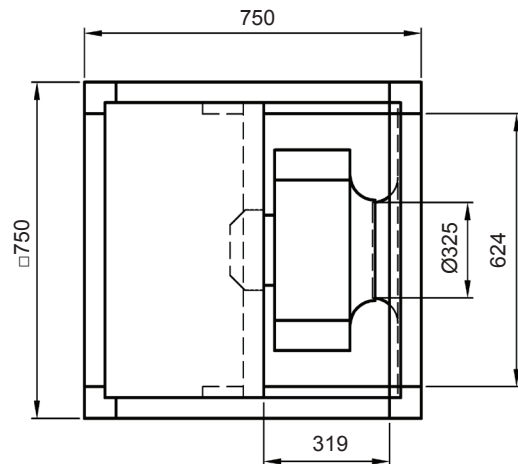

**connection plan*
 FFU-EC 400**

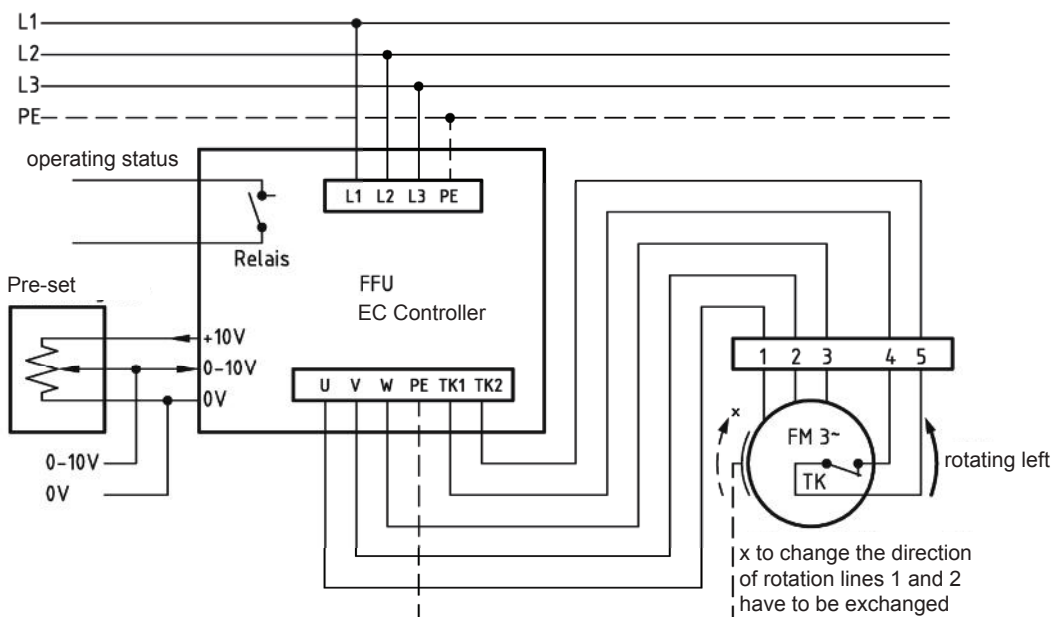

* Connection only according to the enclosed technical documentation.

the silent one



Type: FMBT-EC-40/500/DM1

Erp 2013 2015 2018 x

Performance data

main voltage:	(V)	400 (3~)
frequency:	(Hz)	50
current max.:	(A)	2,7
power input max.:	(kW)	1,2
air flow volume max.:	(m³/h)	7390
statical pressure max.:	(Pa)	700
speed max.:	(rpm)	1350
max. air flow temperature	(°C)	+80
max. ambient temperature	(°C)	+30
capacitor:	(µF)	-

* One discharge! With two discharges the performance increases by approx. 10%

ErP-Data:

total efficiency fan (η_e):	(%)	58,0
installation category:		A
efficiency category:		static
efficiency grade: N	(%)	62
target efficiency (η_{target}):	(%)	52,0
speed controller		yes
year of manufacturing		since 2015
manufacturer:	Fischbach Luft- und Ventilatorentechnik GmbH D-57290 Neunkirchen / HRB 5804 Siegen	
order no.		18172750
power input:	(kW)	1,12
air flow volume:	(m³/h)	3868
statical pressure:	(Pa)	557
speed:	(rpm)	1350
specific ratio:		1
disassembling/recycling/disposal:	see page decommission	
installation/operation/maintenance:	see operating and mounting instructions	
measurement for determination of efficiency without additional items		

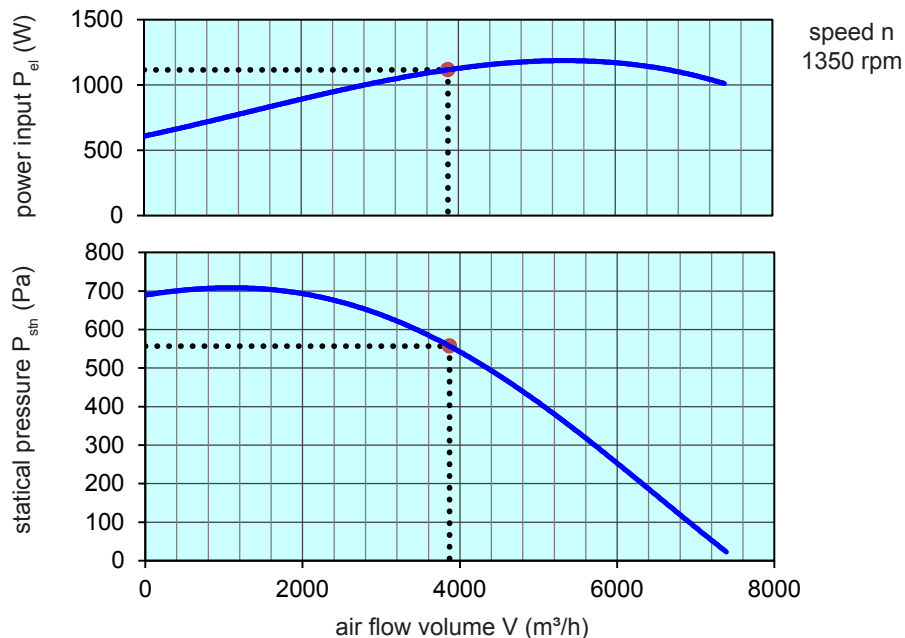

control with	type	order-Nr.
FISCHBACH-frequency-converter	FFU3-21-4	63760
FISCHBACH-Pre-set 0-10V (optional accessories)	FS 10	69460

Technical documentation according to page: **General information**