

Series: VENTILATION UNIT VN standard
with FISCHBACH COMPACT FAN
Type D/DS

FISCHBACH

Luft- und Ventilatorentechnik GmbH

Type: VN 102 D640/E35

ERP KONFORM

CE -conform



Forgalmazó:
Oxyma Systems Kft.
3433 Nyékládháza, Ady Endre u. 49/A

phone: +36 (30) 665-5982
internet: www.fischbach-air.hu
email: oxyma@oxyma.hu

Technical Data

weight:	(kg)	33
material housing:	aluminum/plastic steel, galvanized	
material impeller:	steel, galvanized	
direction of rotation:	left	
motor protection class:	IP 65	
insulation class:	F	
motor protection:	thermal contact	

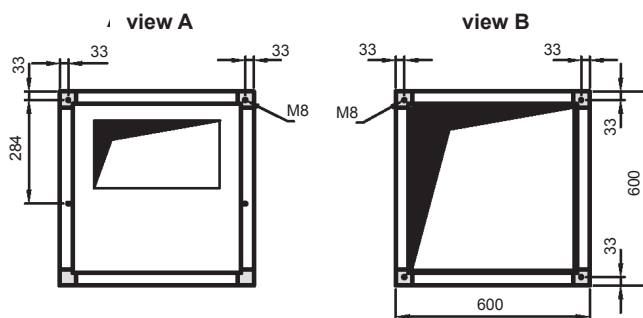
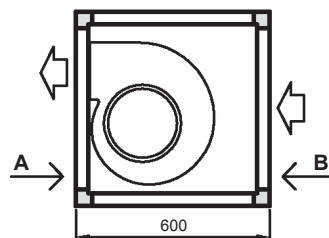

connection plan
0.11-1 I

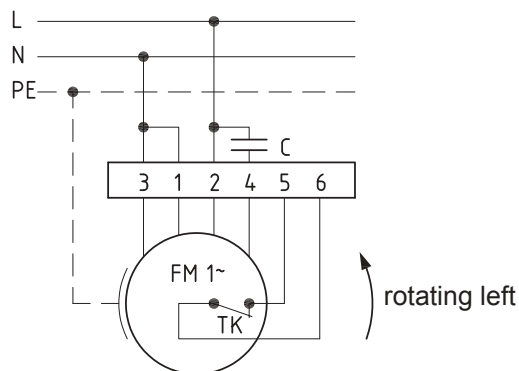

100% controllable

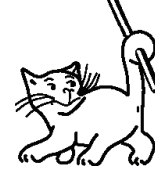

the silent one

Series: VENTILATION UNIT VN standard

with FISCHBACH COMPACT FAN
Type D/DS

FISCHBACH

Luft- und Ventilatorentechnik GmbH

Type: VN 102 D640/E35

Erp 2015 2016 x 2018

Performance data

main voltage:	(V)	230 (1~)
frequency:	(Hz)	50
current max.:	(A)	4,0
power input max.:	(kW)	0,85
air flow volume max.:	(m³/h)	3390
statical pressure max.:	(Pa)	473
speed max.:	(rpm)	1431
supply air temperature:	(°C)	-20... +60
capacitor:	(µF)	20

ErP-Data:

total efficiency fan (η_e):	(%)	31,7
installation category:		A
efficiency category:		static
efficiency grade: N	(%)	35
target efficiency (η_{target}):	(%)	31,7
speed controller		no
year of manufacturing		since 2015
manufacturer:	Fischbach Luft- und Ventilatorentechnik GmbH D-57290 Neunkirchen / HRB 5804 Siegen	
order no.:		58412030
power input:	(kW)	0,59
air flow volume:	(m³/h)	2160
statical pressure:	(Pa)	312
speed:	(rpm)	1318
specific ratio:		1

disassembling/recycling/disposal: see page decommission
installation/operation/maintenance: see operating and mounting instructions
measurement for determination of efficiency without additional items

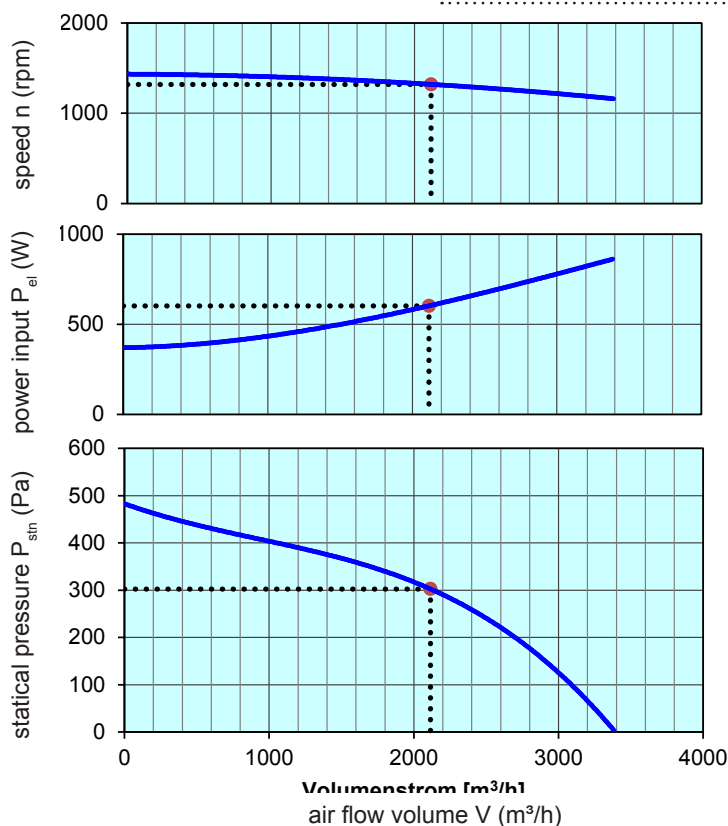

Voltage Control	type	order.-no.
FISCHBACH-Speed-Controller, stepless	FDR 55	6163
FISCHBACH-Speed-Controller, stepwise	FDR 750	6202
FISCHBACH-Automatic-Control	FRA 55	6252
FISCHBACH-Control-Unit	FRE 6	63001

Technical documentation according to page: **General information**