

**Series: VENTILATION UNIT VN standard**  
with FISCHBACH COMPACT FAN  
Type D/DS

**FISCHBACH**  
Luft- und Ventilatorentechnik GmbH

**Type: VN 407 DS9-001/D5**

**ERP KONFORM**



**CE** -conform

**Forgalmazó:**  
Oxyma Systems Kft.  
3433 Nyékládháza, Ady Endre u. 49/A

phone: +36 (30) 665-5982  
internet: www.fischbach-air.hu  
email: oxyma@oxyma.hu

**Technical Data**

weight:	(kg)	118
material housing:	aluminum/plastic steel, galvanized	
material impeller:	steel, galvanized	
direction of rotation:	left	
motor protection class:	IP 65	
insulation class:	F	
motor protection:	thermal contact	

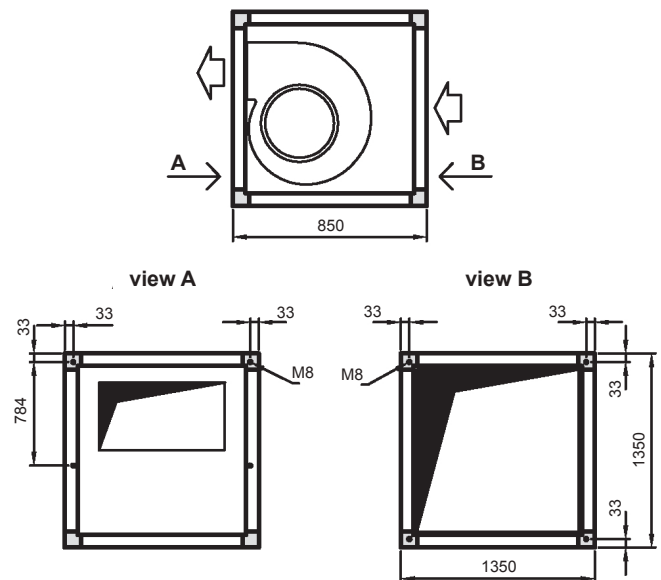

**connection plan**  
0.13-2 I

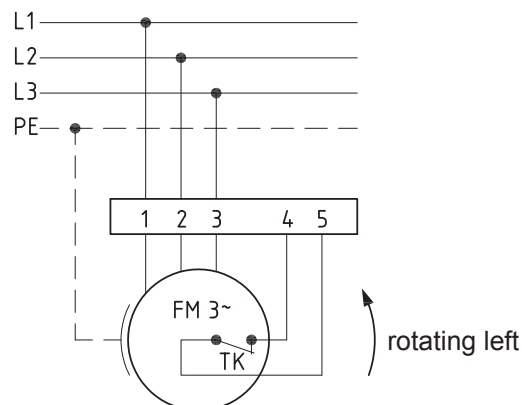

the silent one

# Series: VENTILATION UNIT VN standard

with FISCHBACH COMPACT FAN

Type D/DS

# FISCHBACH

Luft- und Ventilatorentechnik GmbH

## Type: VN 407 DS9-001/D5

Erp 2013 2015 x 2018

### Performance data

main voltage:	(V)	400 (3~)
frequency:	(Hz)	50
current max.:	(A)	19,5
power input max.:	(kW)	9,6
air flow volume max.:	(m³/h)	14560
statical pressure max.:	(Pa)	1500
speed max.:	(rpm)	1458
supply air temperature:	(°C)	-25... see diagram
capacitor:	(µF)	-

### ErP-Data:

total efficiency fan ( $\eta_e$ ):	(%)	43,0
installation category:		A
efficiency category:		static
efficiency grade: N	(%)	44
target efficiency ( $\eta_{target}$ ):	(%)	43,0
speed controller		no
year of manufacturing		since 2015
manufacturer:	Fischbach Luft- und Ventilatorentechnik GmbH D-57290 Neunkirchen / HRB 5804 Siegen	
order no.:		58441085
power input:	(kW)	7,0
air flow volume:	(m³/h)	10240
statical pressure:	(Pa)	1058
speed:	(rpm)	1393
specific ratio:		1

disassembling/recycling/disposal: see page decommission

installation/operation/maintenance: see operating and mounting instructions

measurement for determination of efficiency without additional items

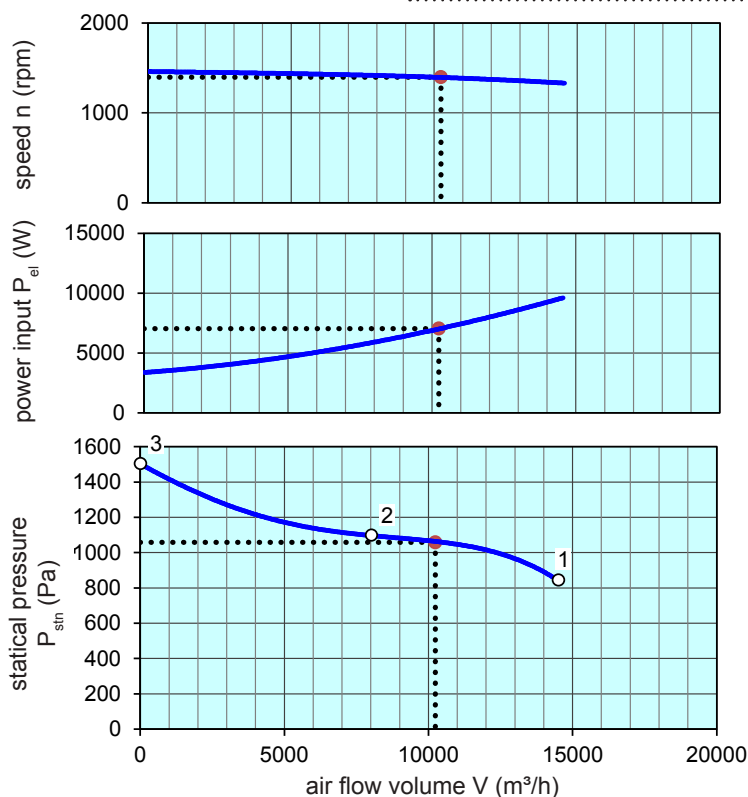

max. permissible ambient temperature from point 1-2: 40°C  
2-3: 60°C

control with	type	order.-no.
FISCHBACH-Speed-Controller, stepless	FDR 200/3	6235
FISCHBACH-Speed-Controller, stepwise	FDR 20/3	6177
FISCHBACH-frequency converter	FFU3-21-15	63780

Technical documentation according to page: **General information**