

Series: COMPACT-FAN Type CE
 EC-MOTOR
 single inlet
 with forward curved blades

FISCHBACH

Luft- und Ventilatorentechnik GmbH

Type: CE890/DM1

ERP KONFORM

CE -conform



manufacturer:
 Fischbach Luft- und Ventilatorentechnik GmbH
 Am Hellerberg 22-24
 D-57290 Neunkirchen
 phone: ++49(0)2735/777-0
 telefax: ++49(0)2735/770-625
 internet: www.fischbach-luft.de
 email: info@fischbach-luft.de

Technical Data

weight:	(kg)	30
material housing:	steel, galvanized	
material impeller:	steel, galvanized	
direction of rotation:	left/right	
protection class:	IP 65	
insulation class:	F	
motor protection:	thermal contact	

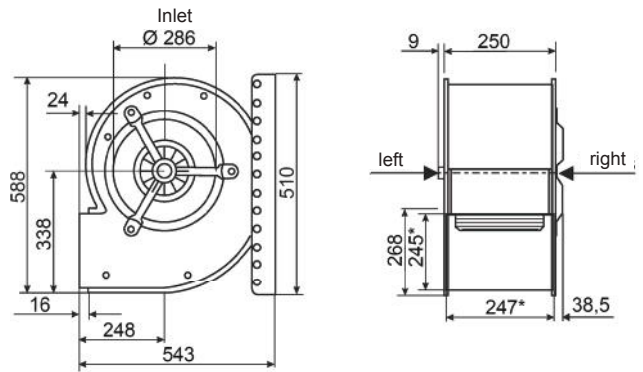

*external dimension of discharge

**connection plan*
 FFU-EC 400**

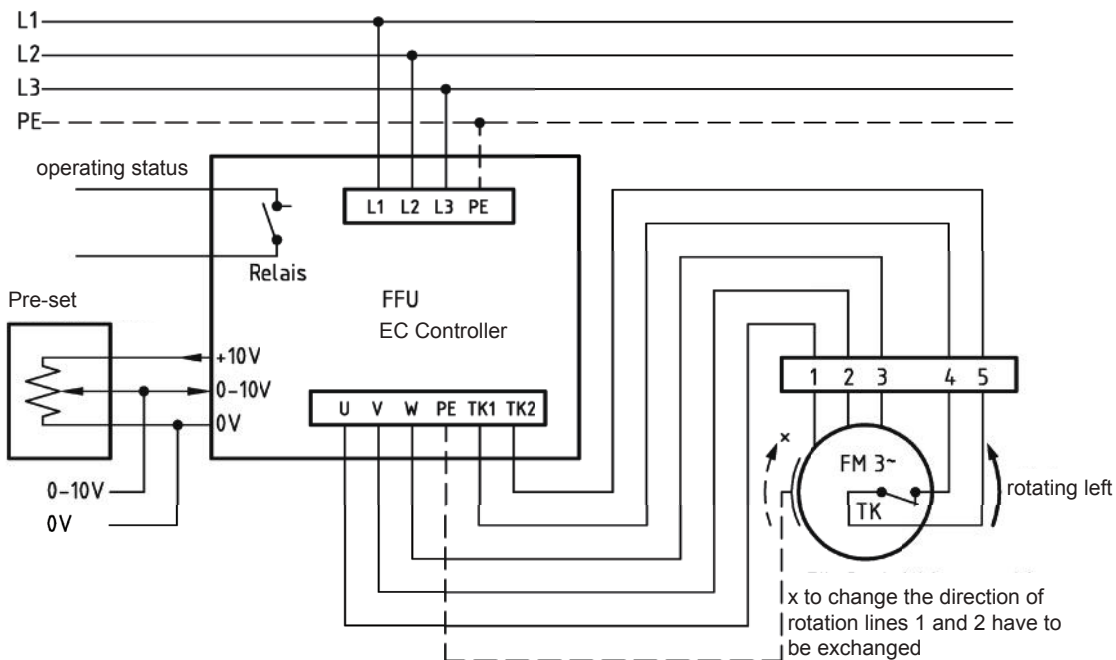

the silent one

* Connection only according to the enclosed technical documentation.

Series: COMPACT-FAN Type CE
EC-MOTOR
 single inlet
 with forward curved blades

FISCHBACH
 Luft- und Ventilatorentechnik GmbH

Type: CE890/DM1

Erp 2013 2015 2018 x

Performance data

main voltage:	(V)	400 (3~)
frequency:	(Hz)	50
current max.:	(A)	5,2
power input max.:	(kW)	2,3
air flow volume max.:	(m³/h)	5825
statical pressure max.:	(Pa)	541
speed max.:	(rpm)	1350
supply air temperature:	(°C)	-25... +50
capacitor:	(µF)	-

ErP-Data:

total efficiency fan (η_e):	(%)	48,3
installation category:		A
efficiency category:		static
efficiency grade: N	(%)	42
target efficiency (η_{target}):	(%)	42,3
speed controller		yes
year of manufacturing		since 2015
manufacturer:	Fischbach Luft- und Ventilatorentechnik GmbH D-57290 Neunkirchen / HRB 5804 Siegen	
order no. (left/right)		18121080/18121380
power input:	(kW)	1,05
air flow volume:	(m³/h)	2783
statical pressure:	(Pa)	604
speed:	(rpm)	1350
specific ratio:		1
disassembling/recycling/disposal: see page decommission		
installation/operation/maintenance: see operating and mounting instructions		
measurement for determination of efficiency without additional items		

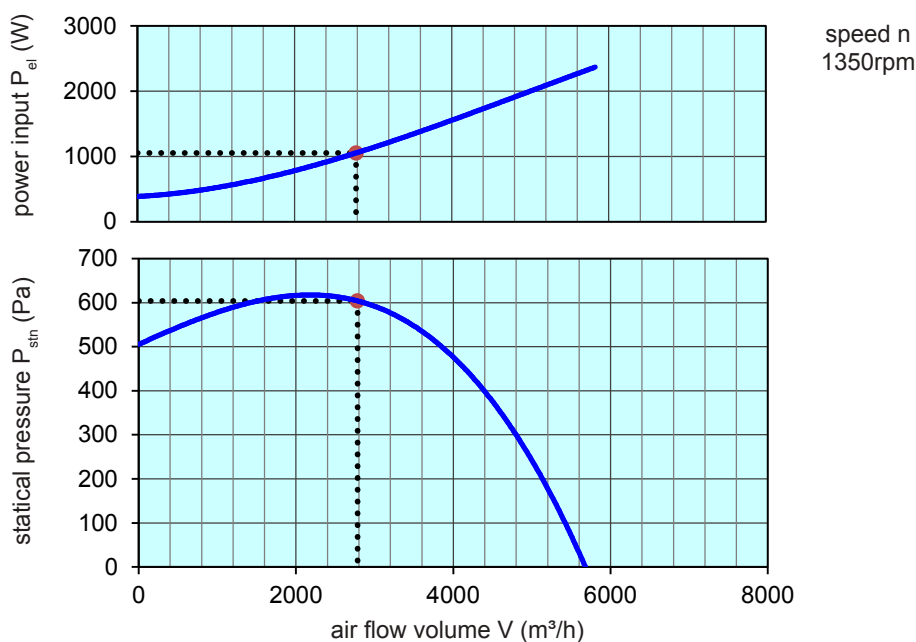

control with	type	order-Nr.
FISCHBACH-frequency-converter	FFU3-21-4	63760
FISCHBACH-Pre-set 0-10V (optional accessories)	FS 10	69460

Technical documentation according to page: **General information**