

Series: COMPACT-FAN Type CE
 EC-MOTOR
 single inlet
 with forward curved blades

FISCHBACH
 Luft- und Ventilatorentechnik GmbH

Type: CE9-090/DM2

ERP KONFORM

CE -conform



Forgalmazó:
 Oxyrna Systems Kft.
 3433 Nyékládháza, Ady Endre u. 49/A

phone: +36 (30) 665-5982
 internet: www.fischbach-air.hu
 email: oxyrna@oxyrna.hu

Technical Data

weight:	(kg)	54
material housing:	steel, galvanized	
material impeller:	steel, galvanized	
direction of rotation:	left/right	
protection class:	IP 65	
insulation class:	F	
motor protection:	thermal contact	

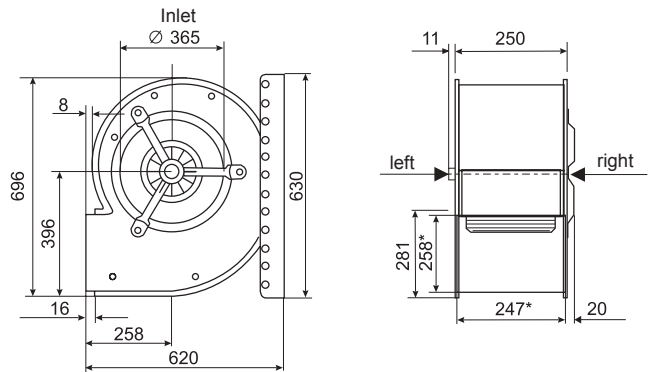

*external dimension of discharge

connection plan*
 FFU-EC 400

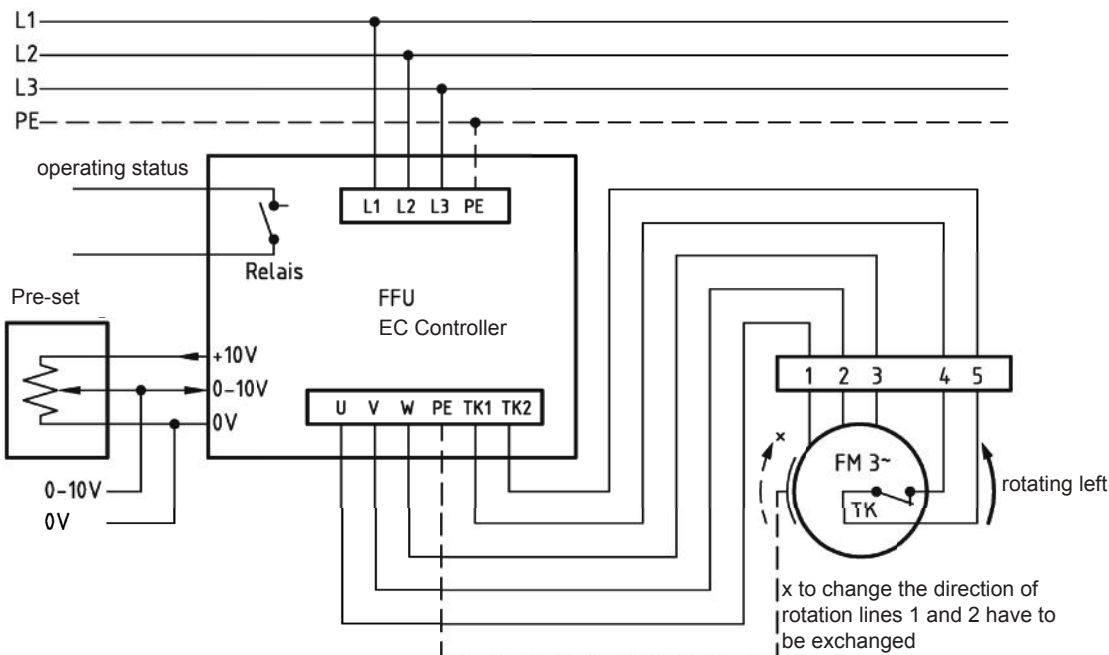

* Connection only according to the enclosed technical documentation.

the silent one



Series: COMPACT-FAN Type CE
EC-MOTOR
 single inlet
 with forward curved blades

FISCHBACH
 Luft- und Ventilatorentechnik GmbH

Type: CE9-090/DM2

Erp 2013 2015 2018 x

Performance data

main voltage:	(V)	400 (3~)
frequency:	(Hz)	50
current max.:	(A)	7,2
power input max.:	(kW)	3,4
air flow volume max.:	(m³/h)	6723
statical pressure max.:	(Pa)	783
speed max.:	(rpm)	1200
supply air temperature:	(°C)	-25... +50
capacitor:	(µF)	-

ErP-Data:

total efficiency fan (η_e):	(%)	45,3
installation category:		A
efficiency category:		static
efficiency grade: N	(%)	42
target efficiency (η_{target}):	(%)	45,1
speed controller		yes
year of manufacturing		since 2015
manufacturer:	Fischbach Luft- und Ventilatorentechnik GmbH D-57290 Neunkirchen / HRB 5804 Siegen	
order no. (left/right)		18121090/18121390
power input:	(kW)	1,66
air flow volume:	(m³/h)	3386
statical pressure:	(Pa)	745
speed:	(rpm)	1200
specific ratio:		1

disassembling/recycling/disposal: see page decommission
 installation/operation/maintenance: see operating and mounting instructions
 measurement for determination of efficiency without additional items

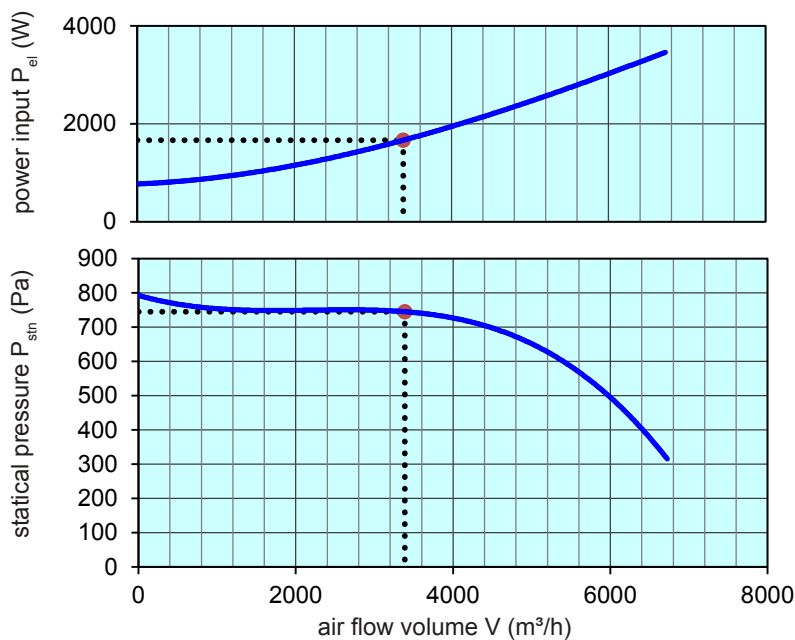

control with	type	order-Nr.
FISCHBACH-frequency-converter	FFU3-21-4	63760
FISCHBACH-Pre-set 0-10V (optional accessories)	FS 10	69460

Technical documentation according to page: **General information**