

**Series:** COMPACT-FAN Type CFE  
 EC-MOTOR  
 single inlet  
 with forward curved blades

**FISCHBACH**

Luft- und Ventilatorentechnik GmbH

**Type:** CFE8-940/DM850

ERP KONFORM



CE -conform

**Forgalmazó:**  
 Oxyrna Systems Kft.  
 3433 Nyékládháza, Ady Endre u. 49/A

phone: +36 (30) 665-5982  
 internet: www.fischbach-air.hu  
 email: oxyrna@oxyrna.hu

**Technical Data**

weight:	(kg)	35,5
material housing:	steel, galvanized	
material impeller:	steel, galvanized	
direction of rotation:	left/right	
protection class:	IP 65	
insulation class:	F	
motor protection:	thermal contact	

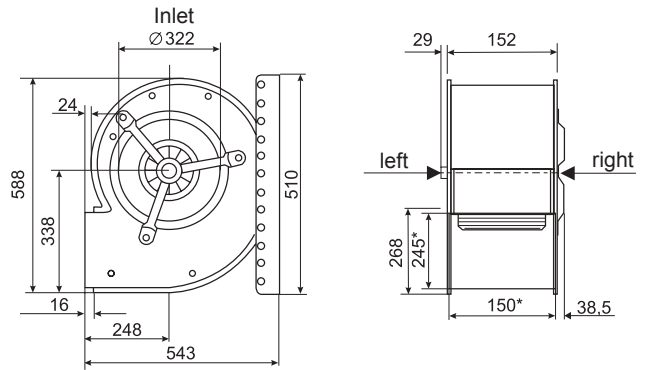

\*external dimension of discharge

**connection plan\*  
 FFU-EC 400**

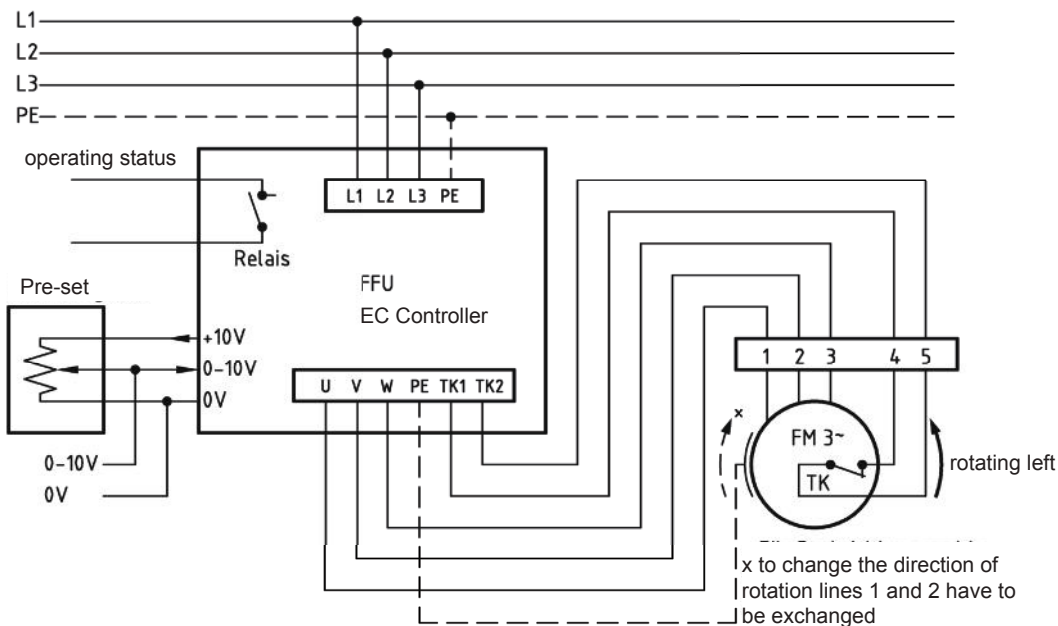

\* Connection only according to the enclosed technical documentation.

the silent one

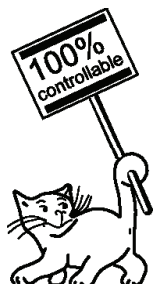

**Series: COMPACT-FAN Type CFE**  
**EC-MOTOR**  
 single inlet  
 with forward curved blades

**FISCHBACH**

Luft- und Ventilatorentechnik GmbH

**Type: CFE8-940/DM850**

Erp 2013 2015 2018 x

**Performance data**

main voltage:	(V)	400 (3~)
frequency:	(Hz)	50
current max.:	(A)	4,6
power input max.:	(kW)	2,0
air flow volume max.:	(m³/h)	3850
statical pressure max.:	(Pa)	700
speed max.:	(rpm)	1350
supply air temperature:	(°C)	-25... +50
capacitor:	(µF)	-

**ErP-Data:**

total efficiency fan ( $\eta_e$ ):	(%)	44,2
installation category:		A
efficiency category:		static
efficiency grade: N	(%)	42
target efficiency ( $\eta_{target}$ ):	(%)	41,1
speed controller		yes
year of manufacturing		since 2015
manufacturer:	Fischbach Luft- und Ventilatorentechnik GmbH D-57290 Neunkirchen / HRB 5804 Siegen	
order no. (left/right)		18121720/18121920
power input:	(kW)	0,86
air flow volume:	(m³/h)	1815
statical pressure:	(Pa)	690
speed:	(rpm)	1350
specific ratio:		1
disassembling/recycling/disposal: see page decommission		
installation/operation/maintenance: see operating and mounting instructions		
measurement for determination of efficiency without additional items		

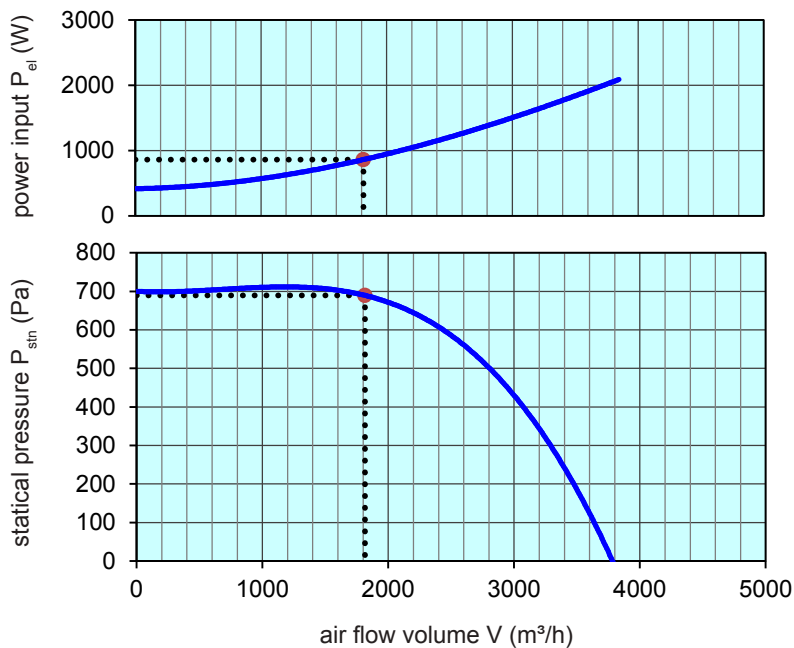

control with	type	order-Nr.
FISCHBACH-frequency-converter	FFU3-21-2.2	63750
FISCHBACH-Pre-set 0-10V (optional accessories)	FS 10	69460

Technical documentation according to page: **General information**