

Series: COMPACT-FAN Type CE
single inlet
with forward curved blades

FISCHBACH
Luft- und Ventilatorentechnik GmbH

Type: CE790/D500

ERP KONFORM

CE -conform



Forgalmazó:
Oxyma Systems Kft.
3433 Nyékládháza, Ady Endre u. 49/A

phone: +36 (30) 665-5982
internet: www.fischbach-air.hu
email: oxyma@oxyma.hu

Technical Data

weight:	(kg)	27
material housing:	steel, galvanized	
material impeller:	steel, galvanized	
direction of rotation:	left/right	
protection class:	IP 65	
insulation class:	F	
motor protection:	thermal contact	

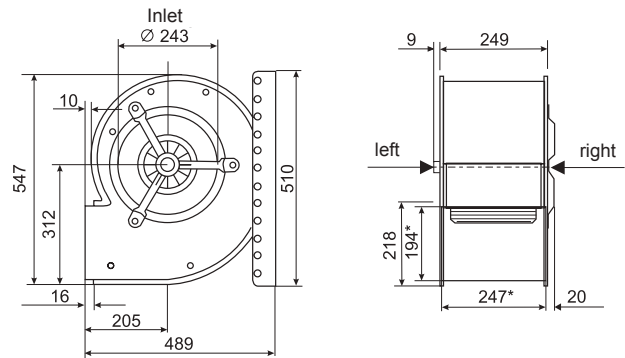

*external dimension of discharge

connection plan
0.13-2 r.

connection plan
0.13-2 l.

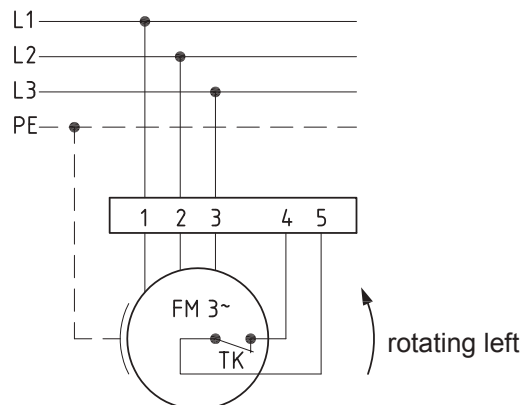
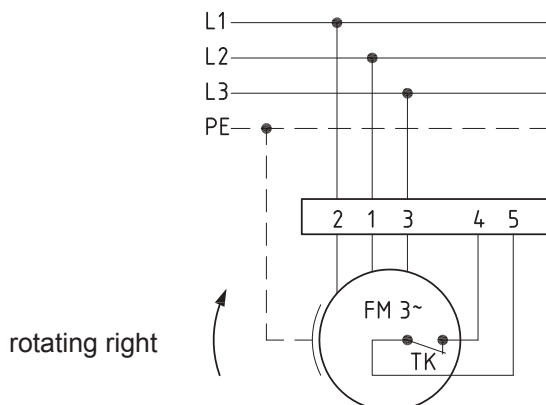

the silent one

Series: COMPACT-FAN Type CE
single inlet
with forward curved blades

FISCHBACH
Luft- und Ventilatorentechnik GmbH

Type: CE790/D500

Erp 2015 2016 x 2018

Performance data

main voltage:	(V)	400 (3~)
frequency:	(Hz)	50
current max.:	(A)	2,2
power input max.:	(kW)	0,99
air flow volume max.:	(m³/h)	3382
statical pressure max.:	(Pa)	510
speed max.:	(rpm)	1419
supply air temperature:	(°C)	-20... +60
capacitor:	(µF)	-

ErP-Data:

total efficiency fan (η_e):	(%)	32,4
installation category:		A
efficiency category:		static
efficiency grade: N	(%)	35
target efficiency (η_{target}):	(%)	32,4
speed controller		no
year of manufacturing		since 2015
manufacturer:	Fischbach Luft- und Ventilatorentechnik GmbH D-57290 Neunkirchen / HRB 5804 Siegen	
order no.:	le/ri	18021230/18021530
power input:	(kW)	0,66
air flow volume:	(m³/h)	2025
statical pressure:	(Pa)	380
speed:	(rpm)	1296
specific ratio:		1

disassembling/recycling/disposal: see page decommission
installation/operation/maintenance: see operating and mounting instructions
measurement for determination of efficiency without additional items

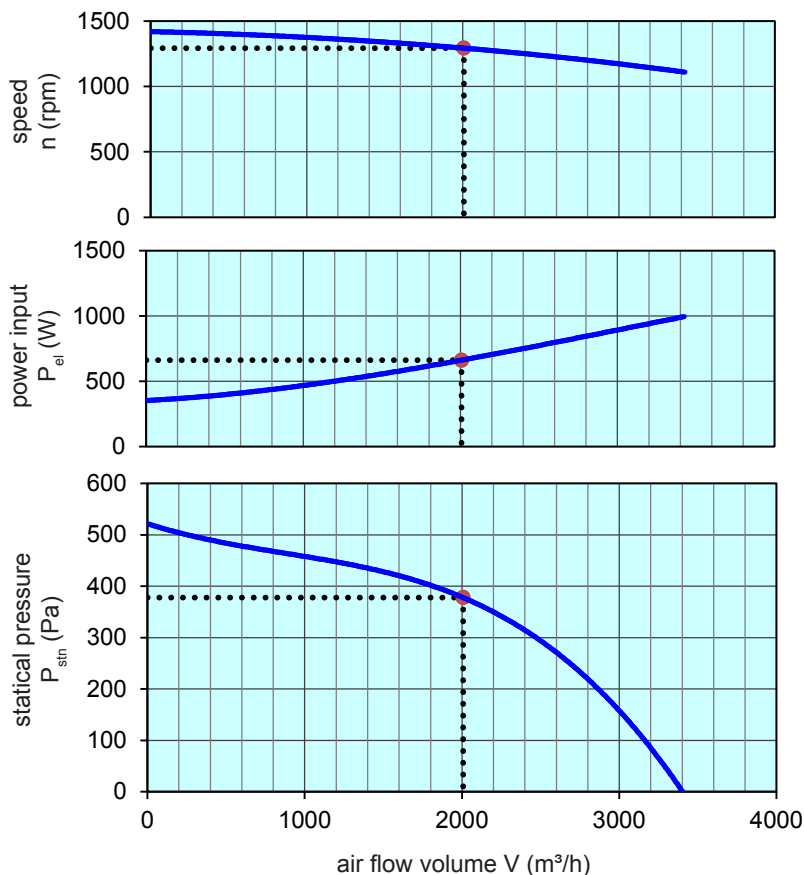

Speed controller / accessories / sound data, please see in the appropriate table

Technical documentation according to page: **General information**