

**Series: COMPACT-FAN Type CE**  
 single inlet  
 with forward curved blades

**FISCHBACH**  
 Luft- und Ventilatorentechnik GmbH

**Type: CE990/D2**

**ERP KONFORM**

**CE** -conform



**Forgalmazó:**  
 Oxyrna Systems Kft.  
 3433 Nyékládháza, Ady Endre u. 49/A

phone: +36 (30) 665-5982  
 internet: www.fischbach-air.hu  
 email: oxyrna@oxyrna.hu

**Technical Data**

weight:	(kg)	54
material housing:	steel, galvanized	
material impeller:	steel, galvanized	
direction of rotation:	left/right	
protection class:	IP 65	
insulation class:	F	
motor protection:	thermal contact	

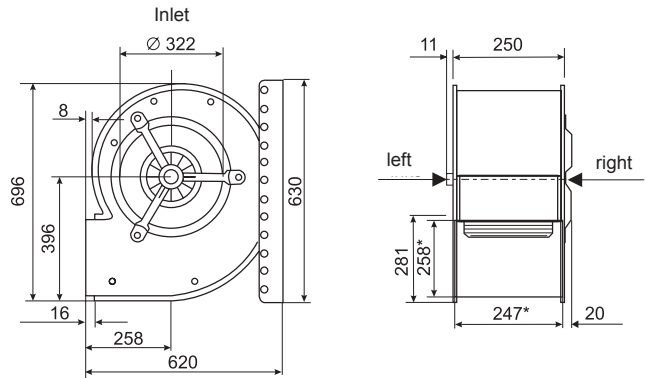

\*external dimension of discharge

connection plan  
 0.13-2 r.

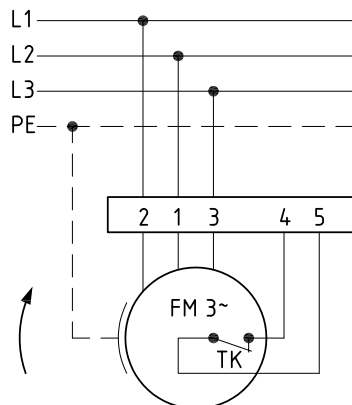

rotating right

connection plan  
 0.13-2 l.

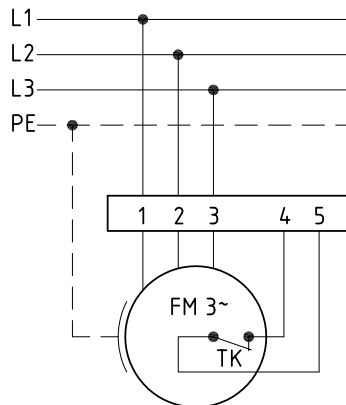

rotating left

the silent one



**Series: COMPACT-FAN Type CE**

single inlet  
with forward curved blades

**FISCHBACH**

Luft- und Ventilatorentechnik GmbH

**Type: CE990/D2**

Erp 2013 2015 x 2018

**Performance data**

main voltage:	(V)	400 (3~)
frequency:	(Hz)	50
current max.:	(A)	6,2
power input max.:	(kW)	2,9
air flow volume max.:	(m³/h)	5921
statical pressure max.:	(Pa)	830
speed max.:	(rpm)	1442
supply air temperature:	(°C)	-25...+60
capacitor:	(µF)	-

**ErP-Data:**

total efficiency fan ( $\eta_e$ ):	(%)	38,9
installation category:		A
efficiency category:		static
efficiency grade: N	(%)	44
target efficiency ( $\eta_{target}$ ):	(%)	38,8
speed controller		no
year of manufacturing		since 2015
manufacturer:	Fischbach Luft- und Ventilatorentechnik GmbH D-57290 Neunkirchen / HRB 5804 Siegen	
order no.: le/ri		18021092/18021392
power input:	(kW)	1,5
air flow volume:	(m³/h)	2800
statical pressure:	(Pa)	750
speed:	(rpm)	1360
specific ratio:		1

disassembling/recycling/disposal: see page decommission

installation/operation/maintenance: see operating and mounting instructions

measurement for determination of efficiency without additional items

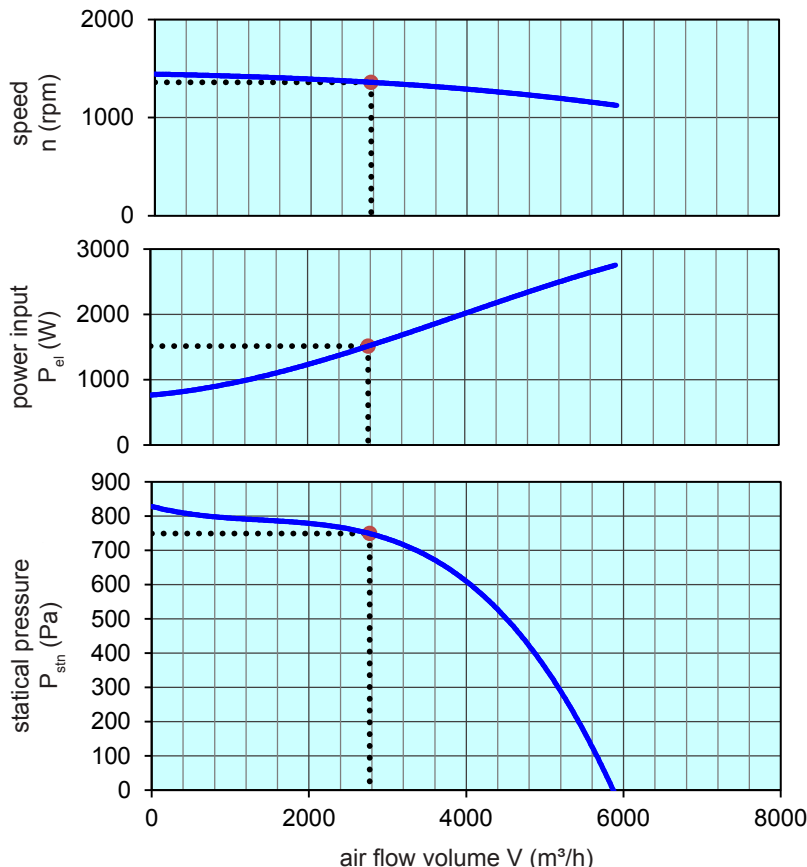

**Speed controller / accessories / sound data**, please see in the appropriate table

Technical documentation according to page: **General information**