

**Series:** COMPACT-FAN Type CFE  
single inlet  
with forward curved blades

**FISCHBACH**  
Luft- und Ventilatorentechnik GmbH

**Type:** CFE540/E1

ERP KONFORM

CE -conform



**Forgalmazó:**  
Oxyrna Systems Kft.  
3433 Nyékládháza, Ady Endre u. 49/A

phone: +36 (30) 665-5982  
internet: www.fischbach-air.hu  
email: oxyrna@oxyrna.hu

**Technical Data**

weight:	(kg)	13,5
material housing:	steel, galvanized	
material impeller:	steel, galvanized	
direction of rotation:	left/right	
protection class:	IP 65	
insulation class:	F	
motor protection:	thermal contact	

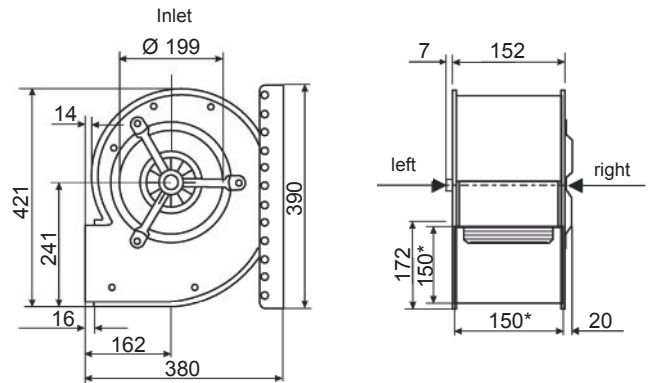

\*external dimension of discharge

connection plan  
0.11-1 r.

connection plan  
0.11-1 l.

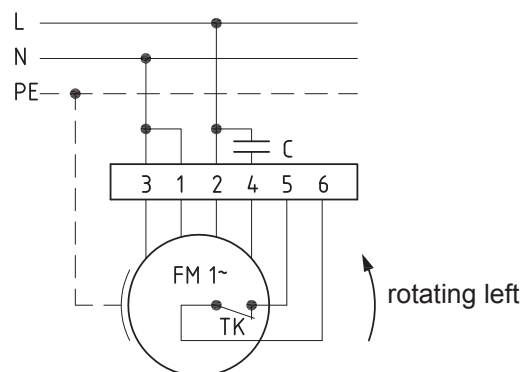
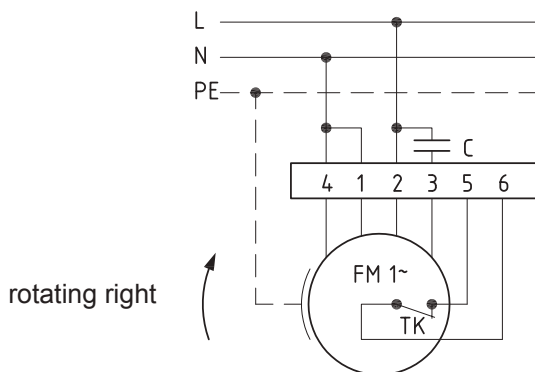

the silent one

Series: **COMPACT-FAN Type CFE**

single inlet  
with forward curved blades

**FISCHBACH**

Luft- und Ventilatorentechnik GmbH

Type: **CFE540/E1**

Erp 2013 2015 2018 x

**Performance data**

main voltage:	(V)	230 (1~)
frequency:	(Hz)	50
current max.:	(A)	1,03
power input max.:	(kW)	0,21
air flow volume max.:	(m <sup>3</sup> /h)	1114
statical pressure max.:	(Pa)	330
speed max.:	(rpm)	1392
supply air temperature:	(°C)	-25... +60
capacitor:	(µF)	3

**ErP-Data:**

total efficiency fan ( $\eta_e$ ):	(%)	31,6
installation category:		A
efficiency category:		static
efficiency grade: N	(%)	42
target efficiency ( $\eta_{target}$ ):	(%)	30,2
speed controller		no
year of manufacturing		since 2015
manufacturer:	Fischbach Luft- und Ventilatorentechnik GmbH D-57290 Neunkirchen / HRB 5804 Siegen	
order no.: le/ri		18021582/18021782
power input:	(kW)	0,15
air flow volume:	(m <sup>3</sup> /h)	620
statical pressure:	(Pa)	275
speed:	(rpm)	1284
specific ratio:		1

disassembling/recycling/disposal: see page decommission

installation/operation/maintenance: see operating and mounting instructions

measurement for determination of efficiency without additional items

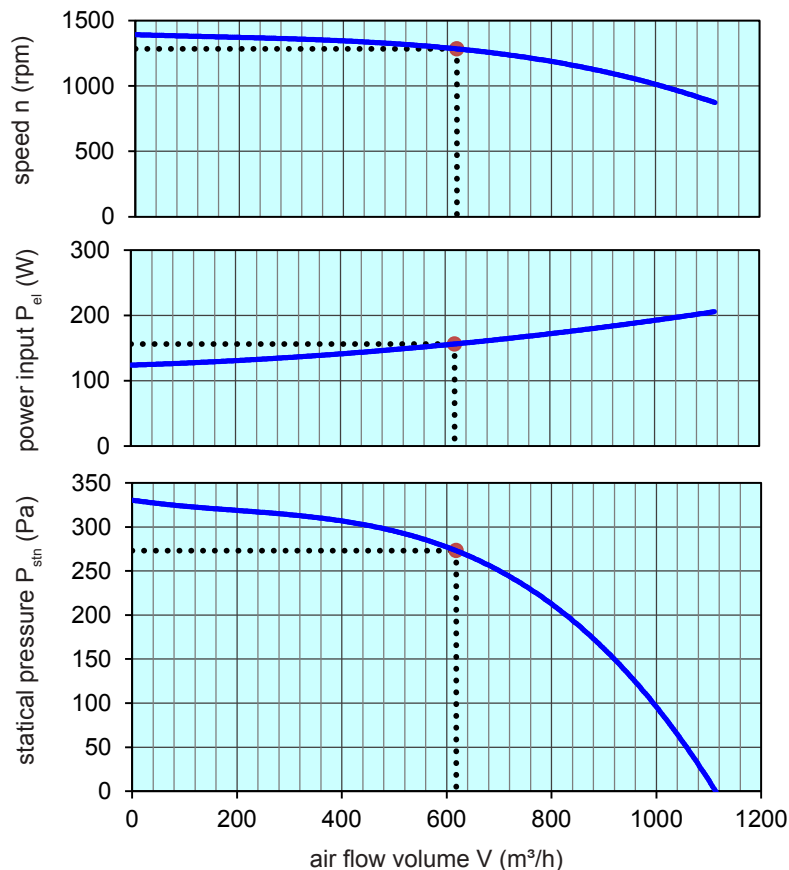

Speed controller / accessories / sound data, please see in the appropriate table

Technical documentation according to page: **General information**