

Series: COMPACT-FAN Type CFE
single inlet
with forward curved blades

FISCHBACH
Luft- und Ventilatorentechnik GmbH

Type: CFE640/E15

ERP KONFORM

CE -conform



Forgalmazó:
Oxyrna Systems Kft.
3433 Nyékládháza, Ady Endre u. 49/A

phone: +36 (30) 665-5982
internet: www.fischbach-air.hu
email: oxyrna@oxyrna.hu

Technical Data

weight:	(kg)	13,5
material housing:	steel, galvanized	
material impeller:	steel, galvanized	
direction of rotation:	left/right	
protection class:	IP 65	
insulation class:	F	
motor protection:	thermal contact	

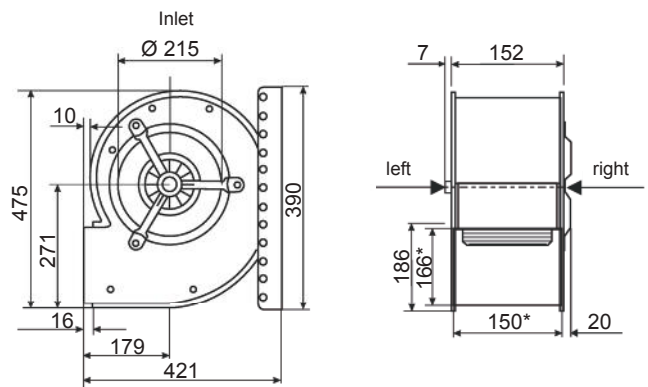

*external dimension of discharge

connection plan
0.11-1 r.

connection plan
0.11-1 l.

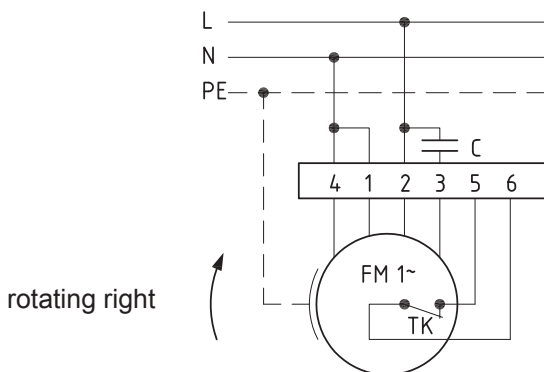

rotating right

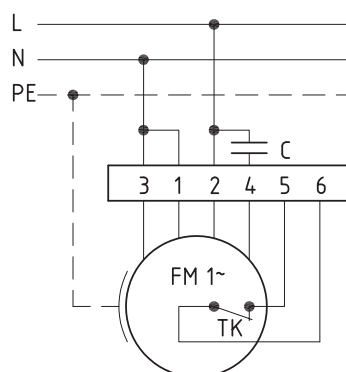

rotating left

the silent one

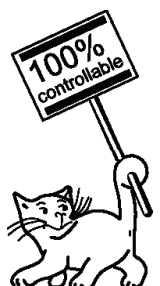

Series: **COMPACT-FAN Type CFE**

single inlet
with forward curved blades

FISCHBACH

Luft- und Ventilatorentechnik GmbH

Type: **CFE640/E15**

Erp 2015 2016 x 2018

Performance data

main voltage:	(V)	230 (1 ~)
frequency:	(Hz)	50
current max.:	(A)	1,66
power input max.:	(kW)	0,37
air flow volume max.:	(m³/h)	1560
statical pressure max.:	(Pa)	370
speed max.:	(rpm)	1412
supply air temperature:	(°C)	-20... +60
capacitor:	(µF)	10

ErP-Data:

total efficiency fan (η_e):	(%)	27,2
installation category:		A
efficiency category:		static
efficiency grade: N	(%)	35
target efficiency (η_{target}):	(%)	26,9
speed controller		no
year of manufacturing		since 2015
manufacturer:	Fischbach Luft- und Ventilatorentechnik GmbH D-57290 Neunkirchen / HRB 5804 Siegen	
order no.:	le/ri	18021602/18021802
power input:	(kW)	0,27
air flow volume:	(m³/h)	1015
statical pressure:	(Pa)	260
speed:	(rpm)	1295
specific ratio:		1

disassembling/recycling/disposal: see page decommission
installation/operation/maintenance: see operating and mounting instructions
measurement for determination of efficiency without additional items

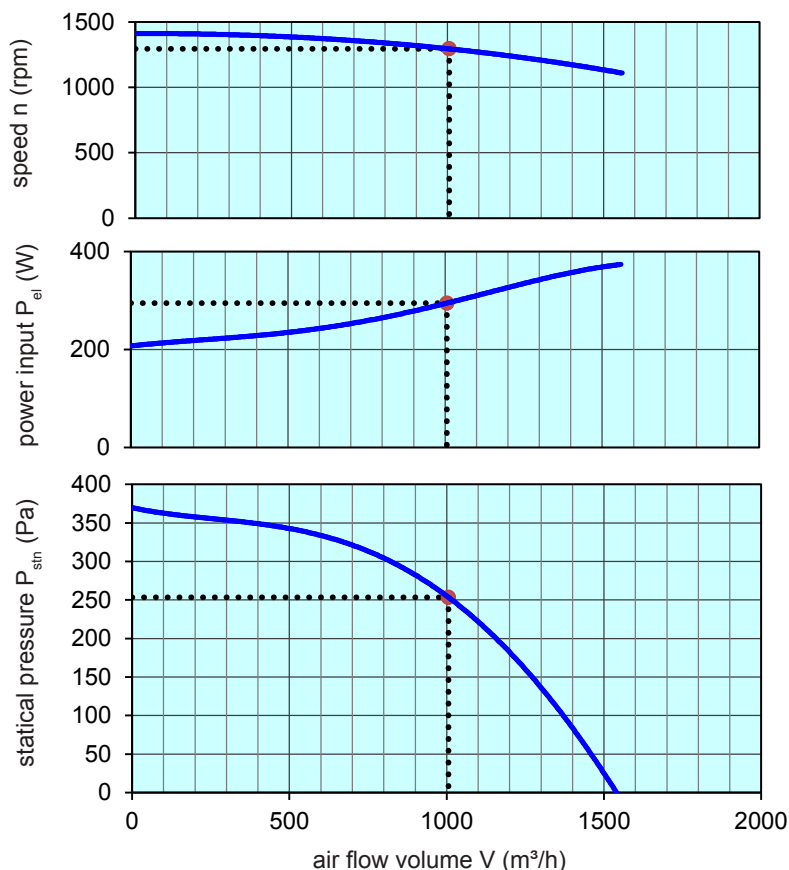

Speed controller / accessories / sound data, please see in the appropriate table

Technical documentation according to page: **General information**