

Series: COMPACT-FAN Type D/DS

double inlet
with forward curved blades

FISCHBACH

Luft- und Ventilatorentechnik GmbH

Type: D770/D1

ERP KONFORM

CE -conform



Forgalmazó:

Oxyrna Systems Kft.
3433 Nyékládháza, Ady Endre u. 49/A

phone: +36 (30) 665-5982
internet: www.fischbach-air.hu
email: oxyrna@oxyrna.hu

Technical Data

weight:	(kg)	30
material housing:	steel, galvanized	
material impeller:	steel, galvanized	
direction of rotation:	left	
protection class:	IP 65	
insulation class:	F	
motor protection:	thermal contact	

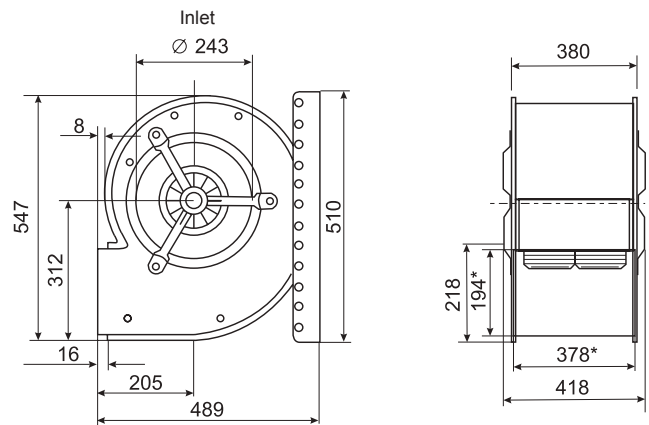

*external dimension of discharge

**connection plan
0.13-2 I.**

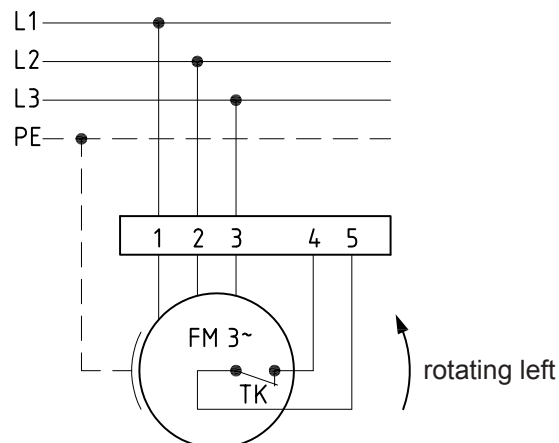

the silent one

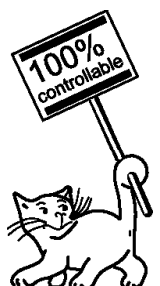

Series: **COMPACT-FAN Type D/DS**

double inlet
with forward curved blades

FISCHBACH

Luft- und Ventilatorentechnik GmbH

Type: **D770/D1**

ErP 2013 2015 2018 x

Performance data

main voltage:	(V)	400 (3~)
frequency:	(Hz)	50
current max.:	(A)	4,23
power input max.:	(kW)	2,1
air flow volume max.:	(m³/h)	6477
statical pressure max.:	(Pa)	650
speed max.:	(rpm)	1464
supply air temperature:	(°C)	-25... +60
capacitor:	(µF)	-

ErP-Data:

total efficiency fan (η_e):	(%)	42,3
installation category:		A
efficiency category:		static
efficiency grade: N	(%)	42
target efficiency (η_{target}):	(%)	41,7
speed controller		no
year of manufacturing		since 2015
manufacturer:	Fischbach Luft- und Ventilatorentechnik GmbH D-57290 Neunkirchen / HRB 5804 Siegen	
order no.		18011952
power input:	(kW)	0,96
air flow volume:	(m³/h)	2635
statical pressure:	(Pa)	555
speed:	(rpm)	1422
specific ratio:		1

disassembling/recycling/disposal: see page decommission
installation/operation/maintenance: see operating and mounting instructions
measurement for determination of efficiency without additional items

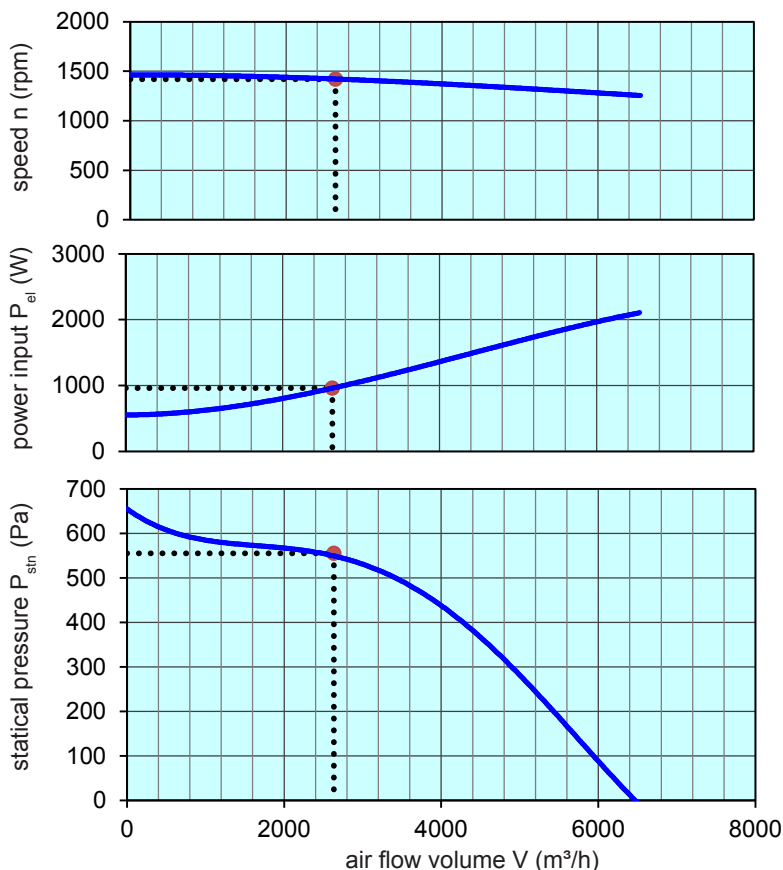

Speed controller / accessories / sound data, please see in the appropriate table

Technical documentation according to page: **General information**