

Series: COMPACT-FAN Type D/DS

double inlet
with forward curved blades

FISCHBACH

Luft- und Ventilatorentechnik GmbH

Type: D770/E80

ERP KONFORM

CE -conform



Forgalmazó:

Oxyma Systems Kft.
3433 Nyékládháza, Ady Endre u. 49/A

phone: +36 (30) 665-5982
internet: www.fischbach-air.hu
email: oxyma@oxyma.hu

Technical Data

weight:	(kg)	30
material housing:	steel, galvanized	
material impeller:	steel, galvanized	
direction of rotation:	left	
protection class:	IP 65	
insulation class:	F	
motor protection:	thermal contact	

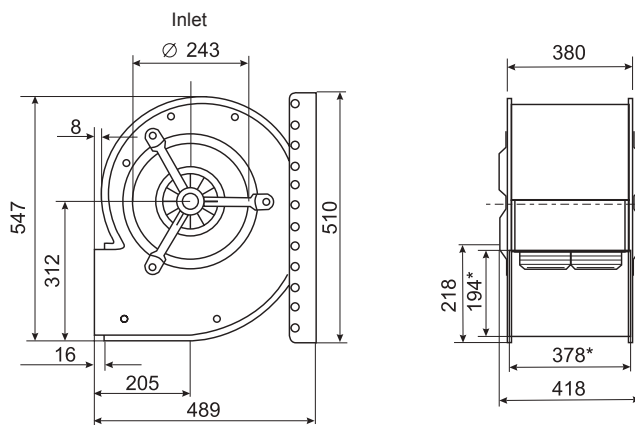

*external dimension of discharge

connection plan

0.11-1 I.

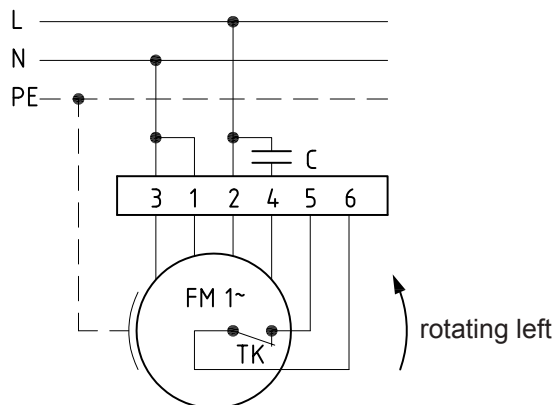

the silent one



Series: COMPACT-FAN Type D/DS

double inlet
with forward curved blades

FISCHBACH

Luft- und Ventilatorentechnik GmbH

Type: D770/E80

ErP 2013 2015 x 2018

Performance data

main voltage:	(V)	230 (1~)
frequency:	(Hz)	50
current max.:	(A)	8,0
power input max.:	(kW)	1,8
air flow volume max.:	(m³/h)	6004
statical pressure max.:	(Pa)	677
speed max.:	(rpm)	1453
supply air temperature:	(°C)	-25... see diagram
capacitor:	(µF)	30

ErP-Data:

total efficiency fan (η_e):	(%)	41,9
installation category:		A
efficiency category:		static
efficiency grade: N	(%)	44
target efficiency (η_{target}):	(%)	37,6
speed controller		no
year of manufacturing		since 2015
manufacturer: Fischbach Luft- und Ventilatorentechnik GmbH D-57290 Neunkirchen / HRB 5804 Siegen		
order no.		18012042
power input:	(kW)	0,99
air flow volume:	(m³/h)	2904
statical pressure:	(Pa)	514
speed:	(rpm)	1383
specific ratio:		1
disassembling/recycling/disposal: see page decommission		
installation/operation/maintenance: see operating and mounting instructions		
measurement for determination of efficiency without additional items		

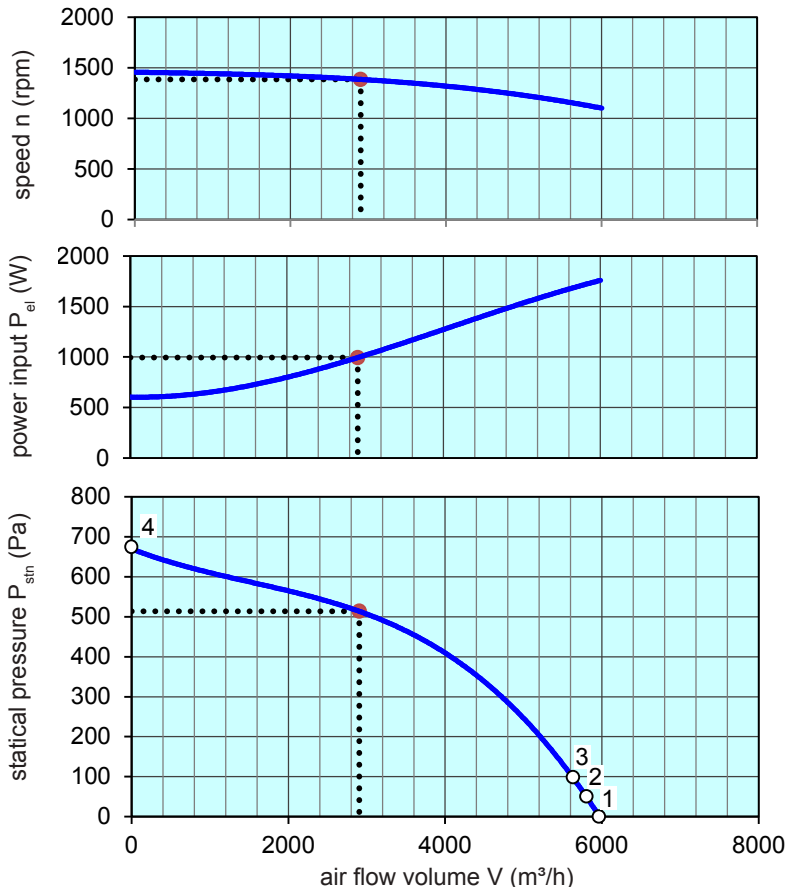

max. permissible ambient temperature from point 1-2: 40°
2-3: 50°
3-4: 60°

Speed controller / accessories / sound data, please see in the appropriate table

Technical documentation according to page: **General information**